

National Highways Authority of India
(Ministry of Road Transport & Highways)



PATEL DARAH-JHALAWAR HIGHWAY PRIVATE LIMITED

CONSTRUCTION OF 4-LANE ROAD ON NH-12 (NEW NH-52) FROM Km. 299.000 TO Km. 346.540 (DESIGN CHAINAGE 9.860 TO 58.740) (DARAH – JHALAWAR – TEENDHAR) IN THE STATE OF RAJASTHAN UNDER NHDP PHASE-III ON HYBRID ANNUITY PROJECT.

INDEPENDENT ENGINEER

LEA ASSOCIATES SOUTH ASIA PVT. LTD

MONTHLY PROGRESS REPORT

For The Month of August-2019

Executive Summary

The old National Highway 12 runs through two big states Rajasthan and Madhya Pradesh. The total length of the old NH- 12 was 897/00 Km. The length of Old NH 12 was 408/700 Km in the state of Rajasthan. Recently MORTH has amended the number and length of the National highways. The old NH 12 in the state of Rajasthan has become the part of the New National highway 52. The New NH 52 starting from its junction with NH-7 near Sangrur in the state of Punjab connecting Narwana, Hisar in the state of Haryana, Fatehpur, Jaipur, Tonk, Kota, Aklera in the state of Rajasthan, Rajgarh, Biora, Dewas, Indore, Sendhwa in the state of Madhya Pradesh, Dhule, Aurangabad, bed, Osmanabad, Solapur in the state of Maharashtra, Bijapur, Hubli and terminating at its junction with NH-66 near Ankola in the state of Karnataka.

The Project stretch Darah-Teendhar is connected to Jaipur at one end and it is connected to Bhopal at the other end. The project highway is very important highway as it connects the Capital of Rajasthan states and National capital of country through Jaipur- Delhi Highway.

The project highway is very important highway as it connects to two state Rajasthan and Madhya Pradesh. The Darah-Jhalawar-Teendhar section of National Highway has moderate traffic density. In addition to this there are few sections where alignment needs geometric improvements to maintain riding quality of highway and safe movement of vehicles. Apart from this the present alignment of NH is passing through various congested towns and villages. All of the above factors are demanding the existing 2-lane highway to be developed as 4-lane divided carriageway with bypass provisions in congested towns/ villages.

The Project Highway traverses through two districts viz. Kota and Jhalawar in Rajasthan State. The project study corridor starts at the end of ROB approach near to Darah at km 289+500 and passes through five major towns Darah, Sarvada, Dabadeh, Suket and Jhalawar, and it ends at Teendhar, Existing km 346.540 Km. Existing road width is 2 lane standard. The Existing ROW varies from 15 m to 30 m. The entire project length is under the administrative control of PIU Kota.

Project Synopsis

National Highways Authority of India plans to undertake the Construction of 4-lane Road on NH-12 (New NH-52) from Km 299.000 to 346.540 (Design Chainage From 9.860 to 58.740) (Darah-Jhalawar-Teendhar section) in the State of Rajasthan under NHDP Phase-III on Hybrid Annuity Mode (Length 48.880 Km.) – Package II.

The National Highways Authority of India (NHAI) is undertaking the up-gradation of NH-12 from Existing two lane road to four lane divided carriageway in state of Rajasthan.

The project involves up gradation of 48.88 Km from two-lane to the four-lane divided carriageway. It includes the construction of bridges, intersections, service roads, culverts and related infrastructure, and the installation of signaling systems and signboards. The project will be developed under National Highways Development Project (NHDP) Phase-III on Hybrid Annuity Mode.

Existing and Proposed alignment

SR. NO.	Existing Chainage (Km)		Length	Design Chainage (Km)		Design Length (Km)	Name of Revenue Village
	To	From		To	From		
1	299	299.34	0.34	9.86	10.2	0.34	KAMALPURA
2	299.34	299.74	0.4	10.2	10.6	0.4	KAMALPURA
3	299.74	300.14	0.4	10.6	11	0.4	KAMALPURA
4	300.14	300.44	0.3	11	11.3	0.3	KAMALPURA
5	300.44	300.778	0.338	11.3	11.638	0.338	KOOKARA KHURD
6	300.778	301.255	0.477	11.638	12.115	0.477	MANPURA
7	Dabadeh & Sahrawad a Bypass			12.115	12.3	0.185	MANPURA
8				12.3	13.028	0.728	ZALIMPURA
9				13.028	14.2	1.172	SAHRAWADA
10				14.2	15.661	1.461	TELYA KHERI
11				15.661	17.242	1.581	ASKALI
12				17.242	19.273	2.031	HIRIYA KHERI
13				19.273	19.788	0.515	KHEEMACH
14	308.203	308.515	0.312	19.788	20.1	0.312	KHEEMACH
15	308.515	308.715	0.2	20.1	20.3	0.2	KHEEMACH
16	308.715	308.915	0.2	20.3	20.5	0.2	ATRALIYA
17	308.915	309.079	0.164	20.5	20.664	0.164	ATRALIYA
18	Atraliya Realignment			20.664	21.682	1.018	ATRALIYA
19	310.007	310.125		21.682	21.8	0.118	ATRALIYA
20	310.125	310.325		21.8	22	0.2	ATRALIYA
21	310.325	310.444		22	22.119	0.119	GORDHANPURA

SR. NO.	Existing Chainage (Km)		Length	Design Chainage (Km)		Design Length (Km)	Name of Revenue Village
22	Atraliya Realignment			22.119	22.464	0.345	GORDHANPURA & PAMA KHERI
23	310.789	311.125		22.464	22.8	0.336	PAMA KHERI
24	311.125	311.494		22.8	23.169	0.369	PAMA KHERI
25	311.494	311.625		23.169	23.3	0.131	PAMA KHERI
26	311.625	311.776		23.3	23.451	0.151	PAMA KHERI
27	311.776	312.025		23.451	23.7	0.249	PAMA KHERI
28	312.025	312.725		23.7	24.4	0.7	DEENGASI
29	312.725	312.925		24.4	24.6	0.2	DEENGASI
30	312.925	313.025		24.6	24.7	0.1	DEENGASI
31	313.025	313.125		24.7	24.8	0.1	DEENGASI
32	313.125	313.37		24.8	25.045	0.245	DEENGASI
33	313.37	313.535		25.045	25.21	0.165	DEENGASI
34				25.21	25.254	0.044	DEENGASI
35				25.254	26.124	0.87	UMMEDPURA
36				26.124	27	0.876	RAMPURIYA
37				27	27.358	0.358	SUKET
38				27.358	27.854	0.496	BEER MANDI
39				27.854	28	0.146	SUKET
40				28	29.571	1.571	ARANYA KHURD
41				29.571	31.212	1.641	SURERA
42				31.212	33.617	2.405	BANSYA HERI
43				33.617	35.565	1.948	ARANYA KALAN
44	Suket,			35.565	36.1	0.535	KALMANDI
45	Jhalawar & Jhalrapatan Bypass			36.1	38	1.9	HARISH PURA
46				38	38.537	0.537	RALAYTI
47				38.537	40.343	1.806	RALAYTA
48				40.343	41.784	1.441	JHALRAPATAN
49				41.784	44.224	2.44	MADHOPUR
50				44.224	49.8	5.576	HARIPURA
51				49.8	51.434	1.634	HARIPURA,
52				51.434	52.516	1.082	BANJARI &
53				52.516	54.2	1.684	BHANWARSA
54				54.2	54.565	0.365	BHANWARSA
55	342.895	343.673		54.565	55.343	0.778	BHANWARSA
56	343.673	347.127		55.343	58.74	3.397	BHANWARSA & ROOPAREL

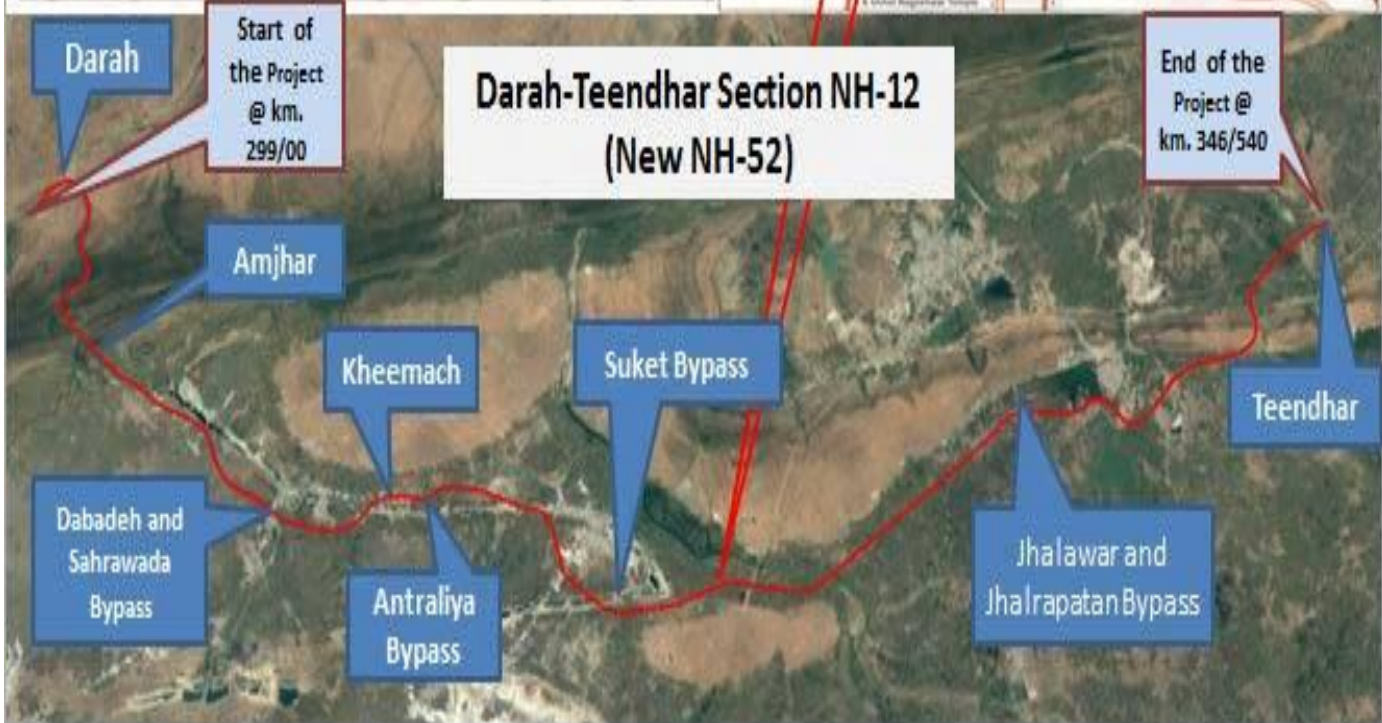
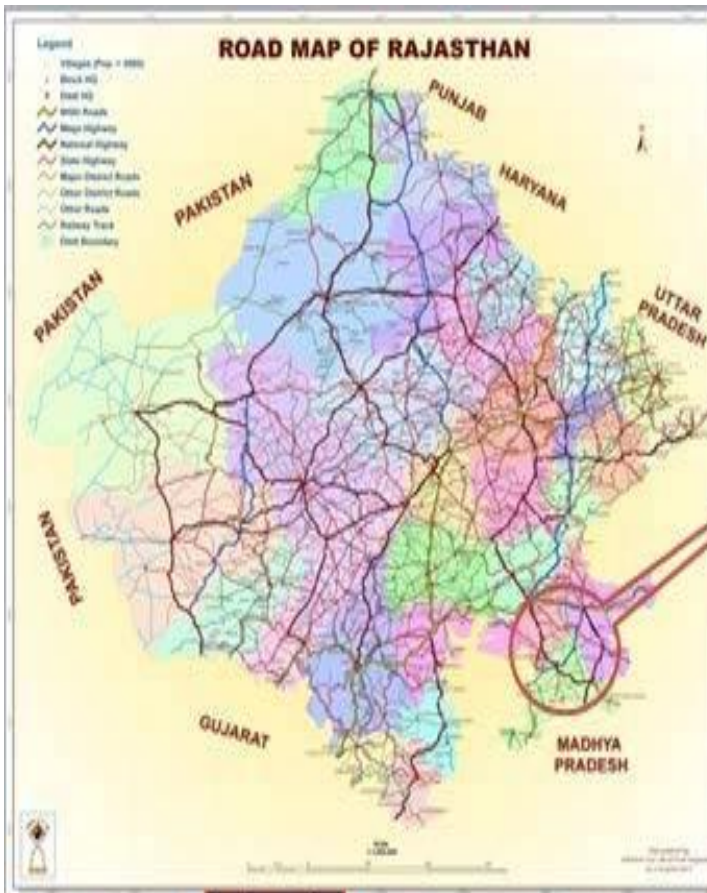

KEY PLAN OF THE PROJECT

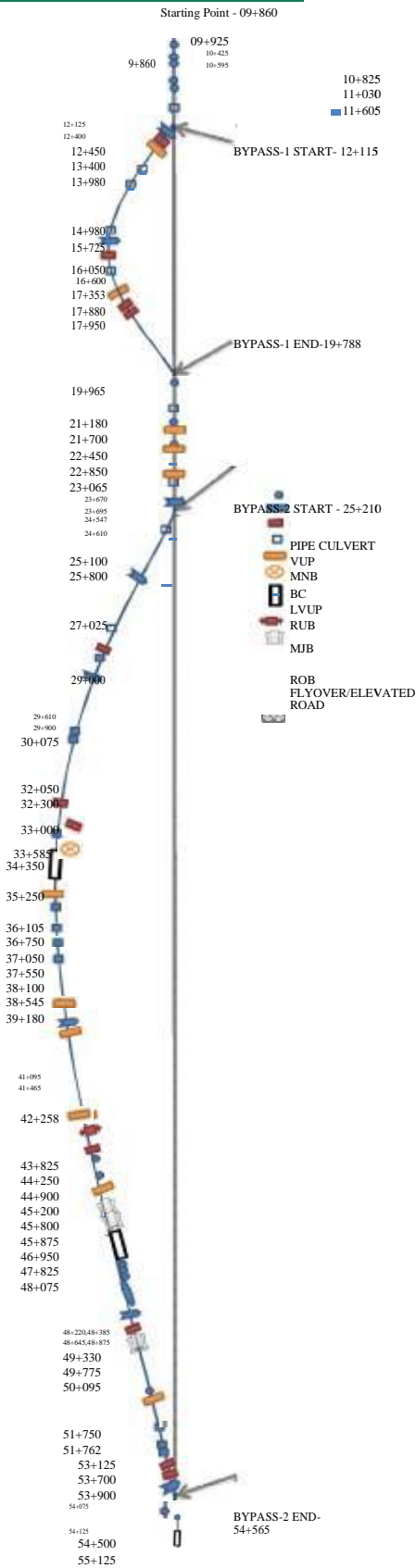

PROJECT SUMMARY

Project	Construction of 4-lane Road on NH-12 New NH-52 from Km 299.000 to 346.540 Design Chainage From 9.860 to 58.740 Darah-Jhalawar-Teendhar Section in the State of Rajasthan under NHDP Phase-III Length 48.880 km Package II on Hybrid Annuity Mode.
Owner/Client	National Highways Authority of India
Concessionaire	Patel Darah Jhalawar Highway Pvt. Ltd.
Independent Engineer	LEA ASSOCIATE SOUTH ASIA PVT. LTD
Project Length (In Km)	48.88 Km
Total Project Cost as per CA	1123.63 Cr.
Concession Period	15 Years
Construction Period	910 Days from the Appointed Date.
Date of Signing of Concession Agreement	16 th November 2017
Appointed Date	24 th May 2018 (Letter ref. No. NHAI /19030/Dara-Teen/Raj/2016/1/120723 dated 09 th July 2018.

1.2 Project Overview

1.2.1 Structures

S. No.	Feature	Description
1	Major Bridge	02 Nos. – (13 x 25mtr) & (13 x 31.6mtr_3-Lane)
2	Elevated Flyover cum MJB	01 Nos. – (20 x 25mtr)
3	Flyovers/ Interchange	03 Nos. (1 Nos. – 4x25mtr.) (2 Nos. – 3 x 24mtr.)
4	ROB/ RUB	1/1 = 2 Nos.
5	Minor bridges	11 Nos.
6	Vehicular underpass	09 Nos. – (1x24mtr)
7	Light Vehicular Underpasses	13 Nos.
8	Culverts (HP/BC) as per CA Additional	37 Nos. (16 Nos. Pipe / 21 Nos. Box) (28 Nos Pipe and 2 nos Box) Total- 44 Nos Pipe and 23 nos Box Culvert
9	RE Wall	14.454 Km
10	Toll Plaza	1 No (16 Lanes)
11	Truck Lay Bys	1 (Both side)
12	Bus Shelter	5 Nos (Both side)
13	Rest Area	1no

Project Milestones

Project Milestone	Condition	Time Line	Date	Financial Progress
I	Commenced construction of Project and achieved 20% of Physical Progress	290 th Day from Appointed date	10 th March 2019	224.73 Cr.
II	Commenced construction of Project and achieved 35% of Physical Progress	430 th Day from Appointed date	28 th July 2019	393.27 Cr.
III	Commenced construction of all Project Facilities and achieved 75% of Physical Progress	690 th Day from Appointed date	13 th April 2020	842.72 Cr.
IV	Completion Of the Project	910 th Day from Appointed date	19 th Nov 2020	1123.63 Cr.

Payment Milestones

Project Milestone	Condition	Status
I	Commenced construction of Project and achieved 10% of Physical Progress	Achieved on 20 th Dec 2018
II	Commenced construction of Project and achieved 30% of Physical Progress	Achieved on 31 st August 2019
III	Commenced construction of all Project Facilities and achieved 50% of Physical Progress	
IV	Commenced construction of all Project Facilities and achieved 75% of Physical Progress	
V	Commenced construction of all Project Facilities and achieved 90% of Physical Progress	

Progress Status as per submitted Programme

Sr.No	Item	Unit	Scope of work as per schedule -B	Planned upto Aug.2019	Progress Achieved upto July-2019	This Month Progress	Cumulative Progress	Program for the month of Sept-2019
Highway Progress (Km.)								
1	C & G	Km	46.25	39.51	38.29	1.09	39.380	0
2	Embankment in Progress	Km	46.25		26.54	0	26.540	0
3	Embankment Top	Km	46.25	19.08	15.19	0	15.190	0
4	Subgrade	Km	46.25	16.4	12.5	0	12.500	0
5	G.S.B	Km	46.25	10.62	11	0.293	11.293	0
6	D.L.C	Km	46.25	10.00	10.513	0.04	10.553	0
7	P.Q.C	Km	46.25	6.95	9.210	0.99	10.200	0
Structure Progress: (No.s)								
1	HPC		16+25=41	15	30.5	1	31.5	0
2	BC		21+4=25	18	16.5	0.5	17	1
3	MNB		11	5	3	2	5	1
4	MJB		2	0	0	0	0	0
5	VUP		9	7	0	0	0	0
6	LVUP		13	10	8	0	8	2
7	Elevated		1	0	0	0	0	0
8	ROB		1	0	0	0	0	0
9	RUB		1	0	0	0	0	0
10	Flyover		3	1	0	0	0	0

1. Cumulative Physical Progress Planned upto March 2020:- 59.99%
2. Physical Progress Planned upto Aug-2019:- 37.86%
3. Physical Progress achieved upto July-2019:- 29.29%
4. Physical progress achieved in Month of Aug-2019:- 00.81%
5. Cumulative physical progress upto Aug-2019:- 30.10%

1.1 Summary of Progress
Summary of Progress (Aug 2019)

Highway Progress:

Sr. No.	Item	Unit	Scope of work	Completed / Work in progress	Balance work
1	C & G	Km	46.25	39.380	06.87
2	Earthwork	Km	46.36	26.540	20.32
3	Sub- Grade	Km	46.36	12.500	35.36
4	GSB	Km	46.36	11.293	35.06
5	DLC (MC)	Km	46.36	10.553	35.80
6	PQC (MC)	Km	46.36	10.200	36.16
7	Earthwork(SR)	Km	28.38	1.550	26.83
8	Sub- Grade(SR)	Km	28.38	0.490	27.89
9	GSB(SR)	Km	28.38	0	28.38
10	WMM (SR)	Km	28.38	0	28.38
11	DBM (SR)	Km	28.38	0	28.38
12	BC (SR)	Km	28.38	0	28.38

Progress of Earthwork is badly affected due to heavy & continuous rain.

Structure Progress Status:-

Sl. No.	Structure Details:-	Unit	Scope	Completed	Work in progress	Balance	Remarks
1	Major Bridge	Nos	2	0	2	0	
2	Elevated Road	Nos	1	0	1	0	
3	Minor Bridge	Nos	11	3	4	4	1 no. deleted
4	Box Culvert	Nos	25	16.5	2.5	6	2 (Additional)
5	Pipe Culvert	Nos	41	31.5	1.5	8	28 (Additional)
6	Vehicular Underpass	Nos	9	0	7	2	
7	Light Vehicular Underpass	Nos	13	8	2	3	
8	Flyover	Nos	3	0	2	1	
9	ROB	Nos	1	0	0	1	
10	RUB	Nos	1	0	0	1	
11	Drain	Km	28.38	10.472	3	14.908	

1. Physical progress Achieved upto 31st Aug 2019- 30.10%

**2. Financial Progress Achieved upto 30th Aug - 33.56%
(377.09 Crs)**

(Financial S- Curve attached at the end)

Utility Shifting Progress

24-05-2018 is the Appointed Date for the project. 85% of the land measuring to Km 41.548 has been handed over by the Authority. 15% of land is balance due to presence of structures, religious structure and other land related issues.

1. Permission for cutting of trees on Government land and forest land received. Cutting of trees in progress. Ref. no 1594 dated 03 / 05 / 2018 (Jhalawar) & 1837-44 dated 22/05/2018(Kota)
2. Electrical Utilities estimate approved in both district Kota & Jhalawar vide letter 41010 & 41011 1/2016- Kota / US – Electric- Kota and Jhalawar / Package-2/7077 dated 24th August 2018. Work for shifting of electrical utilities under progress. Work is balance in existing alignment due to presence of structure.
3. Water Pipelines Estimate is approved vide letter no. _41024 / 1 / 2016- Kota/ US - PHED- Kota / Pkg-II/ 6998 dated 16-08 2018 and 41025 /_1 / 2016- Kota / US /6997 dated 16-08-2018 Shifting work in progress. Work balance only in stretches having LA related issues.
4. HT line have been identified and submitted to concern Department for preparation of estimate. Approval pending.

Details of numbers and length are as below: -

SI No	Utility	Length/ No.	Completed	Balance	Present Status/ Remarks
1	Electric Poles	741 Nos	704	37	Poor progress due to heavy rains & non availability of fronts. Work balance only in stretches having LA related issues. Payment to owners to be expedited.
2	Water Pipe Line (km)	21 Km	18.05	2.95	Poor progress due to heavy rains & non availability of fronts. Work balance only in stretches having LA related issues. Payment to owners to be expedited.
	Crossings	45 Nos.	38	7	

3	HT Line Crossing	6 nos			Estimate submitted to NHAI for Approval.
4	Trees	8156 Nos.	7638 Nos.	518	Cutting in progress

Tree Cutting Status:-

S. No.	District	Category		Nos.	Status			Trees Cut	Balance to be cut	Remarks
					Cutting Permission	Approval Letter No.	Date			
1	Kota	Govt Trees	All	465	Yes	Revenue-III/2018/1837-44	22.05.2018	402	63	
		Private Trees	Fruit	2797	Yes	No.41002/2016-kota/L.A/Ramganjmandi/pkg-2/6243	17.04.2018	2797	0	Disbursement in progress
			Fruitless	1280	Yes			1215	65	
2	Jhalawar	Govt Trees	All	972	Yes	Revenue/18/1594,1861 & 2868	03.05.2018, 25.05.2018 & 06.11.2018	972	0	429 tree cutting approval vide letter no. 2868 dated 06.11.2018
		Private Trees	Fruit	1836	Yes	No.41003/2016-kota/L.A/Jhalawar/pkg-2/6242	17.04.2018	1538	298	Award finalized
			Fruitless	702	Yes			610	92	Disbursement in progress
		Forest		104	yes	F-14()2017/Jhalawar Road/FCA/1998	19.04.2018	104	0	
3	TOTAL			8156				7638	518	94%

- 1) Total No. of trees increased from 7727 to 8156 Nos. because of 429 trees along existing alignment added between Km.54.000 to 58.740. These trees have been cut.

Status of Conditions precedent

a	Provided Performance Security to the Authority	Submitted
b	Executed and procured execution of Escrow Agreement	Submitted. Vide this office letter no. PDJHPL / NHAI / FC / 039 .2018 Dt. 21-05-2018.
c	Executed and procured execution of Substitution Agreement	Submitted. Vide this office letter no. PDJHPL / NHAI / FC / 039 .2018 Dt. 21-05-2018.
d	Procure all Applicable Permits as per Schedule -E	Obtained
e	Executed Financing Agreements and delivered 3 copies duly attested by Director of the Concessionaire	Submitted. Vide this office letter no. PDJHPL / NHAI / FC / 039 .2018 Dt. 21-05-2018
f	Delivered to Authority 3 true copies of Financial Package and Financial Model duly attested by Director of the Concessionaire	Submitted. Vide this office letter no. PDJHPL / NHAI / FC / 039 .2018 Dt. 21-05-2018.
g	Delivered to Authority from Selected Bidder its respective confirmation in original of the correctness of their representations and warranties set forth in Sub Clause (k), (l) and (m) of Clause 7.1 of CA	Submitted
h	Environment Clearance	Done
i	Forest Land Clearance	Stage –II Clearance obtained
j	Wild Life Clearance	NA

Status of Railway Approvals

Proposal Description	Status	Length Impacted	Current Stage	Issues/ Comments
Rail ROB (Ch.44+158)	GAD of ROB Approved	-	Detailed design and drawing Approved by Railways.	Foundation Work in Progress.
RUB (Ch.33+585)	GAD of RUB Approved	-	Detailed design and drawing Approved by Railways.	Falling in DLC issue stretch

ISSUES OF CONCERN: -

- (a) DLC issue from Km- 33+500 to 36+000 and 51+400 to 52+100 (Haripura). The land is yet to be taken under possession.
(b) Court Case Chainages :- Possession of following chainages is balance because of pending cases in SDM court Ramganjmandi.

Sr no.	Chainage		Length (M)
	From	To	
1	10+890	11+000	110
2	20+750	20+850	80
3	21+380	21+500	120
4	24+000	24+100	100
5	30+150	30+270	120
6	30+500	30+585	85
7	41+200	41+300	100
8	42+330	42+400	70
	Total		675

- Disbursement for structures in both the districts Kota & Jhalawar is under progress. Structures in Jhalawar district have been removed except those for which payment released in the month of August 2019. They shall be cleared soon. The process of payment in Kota district is very slow. The same has been reported to authority also. Structures whose payment has been released & not clearing the land have been reported to CALA for providing police protection, but no support has been provided. The Concessionaire has reported the matters to the concerned police stations for providing support. Because of non-removal of these hindrances the progress of electrical and water line shifting is affected, continuity of work fronts cannot be maintained. After disbursement of payment, it will take at-least 4-5 months for physical removal of these hindrance because of monsoon season.
- Arbitration award for villagers of Haripura has been finalized. CALA has intimated the authority for depositing the difference of amount. In Kota district arbitrator has rejected all the cases. Now police protection is to be provided by administration for forceful possession.
- Approval of estimate for shifting of HT line Crossing yet to be done.
- 3A of missing plots in Jhalawar district is pending.
- Disbursement of payment of religious structure within PROW is yet to be done (Jhalawar District).
- The progress of L.A disbursement in Ramganjmandi (Kota district) is very slow and needs to be expedited in order to maintain the continuity of work fronts. Discontinuity of work stretches is having a direct impact on progress of work.
- Award of left over structures / trees is pending for payment, especially in Ramganjmandi tehsil (Kota District).
- The details of hindrances is attached as **Annexure-I**.

MONTHLY PROGRESS REPORT
MONTH OF Aug- 2019

Sr. No.	Name of Test	Number of Tests Conducted									Remarks
		Up To Previous Month			This Month			Total upto Date			
		Passed	Failed	Total No. of Test	Passed	Failed	Total No. of Test	Passed	Failed	Cum. No. of Test	
OGI & Cutting soil											
1	Free Swell Index	311	0	311	0	0	0	311	0	311	
2	Grain Size Analysis	311	0	311	0	0	0	311	0	311	
3	Plasticity Index	311	0	311	0	0	0	311	0	311	
4	Max. Dry Density	311	0	311	0	0	0	311	0	311	
5	CBR	6	0	6	0	0	0	6	0	6	
6	Density of Comp.Layer	5335	143	5478	0	0	0	5335	143	5478	
Borrow Area (Embankment & Subgrade)											
1	Free Swell Index	1340	42	1382	15	0	15	1355	42	1397	
2	Grain Size Analysis	1340	42	1382	15	0	15	1355	42	1397	
3	Plasticity Index	1340	42	1382	15	0	15	1355	42	1397	
4	Max. Dry Density	1352	42	1394	15	0	15	1367	42	1409	
5	CBR	229	28	257	14	0	14	243	28	271	
6	Direct shear test	42	0	42	2	0	2	44	0	44	
Earthwork Field test											
1	Density of Comp.Layer (Emb.)	34384	374	34758	0	0	0	34384	374	34758	
2	Density of Comp.Layer (Sub grade & Earthen shoulder)	4836	62	4898	20	0	20	4856	62	4918	
GSB											
1	Sieve Analysis	218	0	218	6	0	6	224	0	224	
2	Plasticity Index	215	0	215	6	0	6	221	0	221	
3	Max. Dry Density	4	0	4	0	0	0	4	0	4	
4	CBR	2	0	2	0	0	0	2	0	2	
5	Water Absorption	2	0	2	0	0	0	2	0	2	
6	AIV	3	0	3	0	0	0	3	0	3	
7	Density of Comp.Layer	548	17	565	12		12	560	17	577	

Sr. No.	Name of Test	Number of Tests Conducted									Remarks
		Up To Previous Month			This Month			Total upto Date			
		Passed	Failed	Total No. of Test	Passed	Failed	Total No. of Test	Passed	Failed	Cum. No. of Test	
OGL & Cutting soil											
PHYSICAL PROPERTIES OF AGGREGATE FOR CONCRETE											
1	Sieve Analysis of CA	715	0	715	50	0	50	765	0	765	
2	Sieve Analysis of FA	662	0	662	50	0	50	712	0	712	
3	Sieve Analysis of DLC	94	0	94	4	0	4	98	0	98	
4	Sieve Analysis of PQC	91	0	91	2	0	2	93	0	93	
5	Aggregate Impact Value	703	0	703	50	0	50	753	0	753	
6	Flakiness Index	703	0	703	50	0	50	753	0	753	
7	Silt Content	269	0	269	10	0	10	279	0	279	
8	Specific Gravity & W A	14	0	14	0	0	0	14	0	14	
Concrete Mix Design (cube sets)											
1	M15 7 Days	34	0	34	0	0	0	34	0	34	
	28 Days	64	0	64	0	0	0	64	0	64	
2	M20 Kerb 7 Days	6	0	6	2	0	2	8	0	8	
	28 Days	10	0	10	0	0	0	10	0	10	
	M20 7 Days	12	0	12	0	0	0	12	0	12	
	28 Days	18	0	18	0	0	0	18	0	18	
3	M25 7 Days	65	0	65	0	0	0	65	0	65	
	28 Days	104	0	104	0	0	0	104	0	104	
4	M30 7 Days	66	0	66	0	0	0	66	0	66	
	28 Days	121	0	121	0	0	0	121	0	121	
5	M35 7 Days	118	0	118	1	0	1	119	0	119	
	28 Days	199	0	199	2	0	2	201	0	201	
6	M35 Pile 7 Days	68	0	68	0	0	0	68	0	68	
	28 Days	140	0	140	0	0	0	140	0	140	
7	M35 RE block 7 Days	45	0	45	0	0	0	45	0	45	
	28 Days	144	0	144	0	0	0	144	0	144	

Sr. No.	Name of Test	Number of Tests Conducted									Remarks
		Up To Previous Month			This Month			Total upto Date			
		Passed	Failed	Total No. of Test	Passed	Failed	Total No. of Test	Passed	Failed	Cum. No. of Test	
OGI & Cutting soil											
8	M40 7 Days	70	0	70	0	0	0	70	0	70	
	28 Days	111	0	111	0	0	0	111	0	111	
9	M45 7 Days	53	0	53	0	0	0	53	0	53	
	28 Days	101	0	101	0	0	0	101	0	101	
10	M50 7 Days	0	0	0	0	0	0	0	0	0	
	28 Days	0	0	0	0	0	0	0	0	0	
11	M40 PQC 7 Days	118	0	118	12	0	12	130	0	130	
	28 Days	191	0	191	8	0	8	199	0	199	
12	M40 PQC Fl. Strength 7 Days	87	0	87	7	0	7	94	0	94	
	28 Days	104	0	104	0	0	0	104	0	104	
13	DLC 7 Days	27	0	27	0	0	0	27	0	27	
Field Concrete (cube sets)											
1	M15 7 Days	1092	0	1092	39	0	39	1131	0	1131	
	28 Days	1617	0	1617	103	0	103	1720	0	1720	
2	M20 Kerb 7 Days	29	0	29	4	0	4	33	0	33	
	28 Days	31	0	31	29	0	29	60	0	60	
3	M25 7 Days	1246	0	1246	83	0	83	1329	0	1329	
	28 Days	1580	0	1580	166	0	166	1746	0	1746	
4	M30 7 Days	216	0	216	3	0	3	219	0	219	
	28 Days	384	0	384	14	0	14	398	0	398	
5	M35 7 Days	1385	0	1385	133	0	133	1518	0	1518	
	28 Days	2991	0	2991	405	0	405	3396	0	3396	
6	M35 Pile 7 Days	67	0	67	0	0	0	67	0	67	
	28 Days	95	0	95	0	0	0	95	0	95	
7	M35 RE block 7 Days	684	0	684	17	0	17	701	0	701	
	28 Days	2153	0	2153	82	0	82	2235	0	2235	
8	M40 7 Days	58	0	58	4	0	4	62	0	62	

Sr. No.	Name of Test	Number of Tests Conducted									Remarks
		Up To Previous Month			This Month			Total upto Date			
		Passed	Failed	Total No. of Test	Passed	Failed	Total No. of Test	Passed	Failed	Cum. No. of Test	
OGI & Cutting soil											
	28 Days	50	0	50	4	0	4	54	0	54	
9	M45 7 Days	18	0	18	11	0	11	29	0	29	
	28 Days	26	0	26	44	0	44	70	0	70	
10	M50 7 Days	0	0	0	0	0	0	0	0	0	
	28 Days	0	0	0	0	0	0	0	0	0	
11	M40 PQC 7 Days	156	0	156	43	0	43	199	0	199	
	28 Days	143	0	143	35	0	35	178	0	178	
12	M40 PQC Flexural Strength 7 Days	156	0	156	43	0	43	199	0	199	
	28 Days	146	0	146	35	0	35	181	0	181	
13	DLC 7 Days	119	0	119	8	0	8	127	0	127	
14	DLC FDD	469	0	469	14	0	14	483	0	483	
Cement											
1	Fineness	76	0	76	3	0	3	79	0	79	
2	Consistency	76	0	76	3	0	3	79	0	79	
3	Setting Time	76	0	76	3	0	3	79	0	79	
4	Soundness	56	0	56	3	0	3	59	0	59	
5	Compressive Strength										
	a) 3 Days	70	0	70	4	0	4	74	0	74	
	b) 7 Days	68	0	68	5	0	5	73	0	73	
	c) 28 Days	77	0	77	6	0	6	83	0	83	

Sl. No.	Date	Temperature C		Humidity %		Rainfall (mm)
		Min. Temp. (°C)	Max. Temp. (°C)	Min.	Max.	
1	01-08-19	25.9	29.8	78.0	84.5	3.5
2	02-08-19	26.2	30.1	77.1	86.1	0.0
3	03-08-19	26.1	29.8	76.9	84.0	42.5
4	04-08-19	26.0	30.0	74.9	81.8	8.8
5	05-08-19	25.8	30.2	81.1	86.2	0.0
6	06-08-19	24.9	29.8	82.3	88.0	37.6
7	07-08-19	26.4	30.3	79.3	85.9	11.8
8	08-08-19	26.5	31.2	85.0	93.0	21.8
9	09-08-19	24.8	28.2	86.0	96.0	13.6
10	10-08-19	25.1	30.0	72.0	89.0	0.0
11	11-08-19	25.1	29.5	72.0	87.0	0.0
12	12-08-19	25.7	29.9	75.0	91.0	2.2
13	13-08-19	25.4	30.5	74.0	89.0	15.8
14	14-08-19	23.2	27.5	86.0	94.0	135.4
15	15-08-19	23.5	25.1	90.0	92.0	125.2
16	16-08-19	23.2	25.5	89.0	95.0	11.2
17	17-08-19	23.5	27.9	79.0	95.0	1.2
18	18-08-19	23.4	25.3	92.0	96.0	11.4
19	19-08-19	24.0	31.4	74.0	96.0	0.0
20	20-08-19	24.8	31.9	73.0	94.0	0.0
21	21-08-19	21.9	34.0	69.0	94.0	43.4
22	22-08-19	24.1	32.9	69.0	95.0	30.0
23	23-08-19	24.5	31.8	74.0	90.0	0.0
24	24-08-19	23.4	28.1	86.0	94.0	0.0
25	25-08-19	23.5	27.4	86.0	96.0	79.8
26	26-08-19	23.7	29.4	79.0	97.0	18.5
27	27-08-19	24.1	30.4	77.0	96.0	27.4
28	28-08-19	24.8	31.4	79.0	96.0	7.0
29	29-08-19	24.9	32.9	69.0	95.0	6.8
30	30-08-19	24.7	33.1	70.0	94.0	0.0

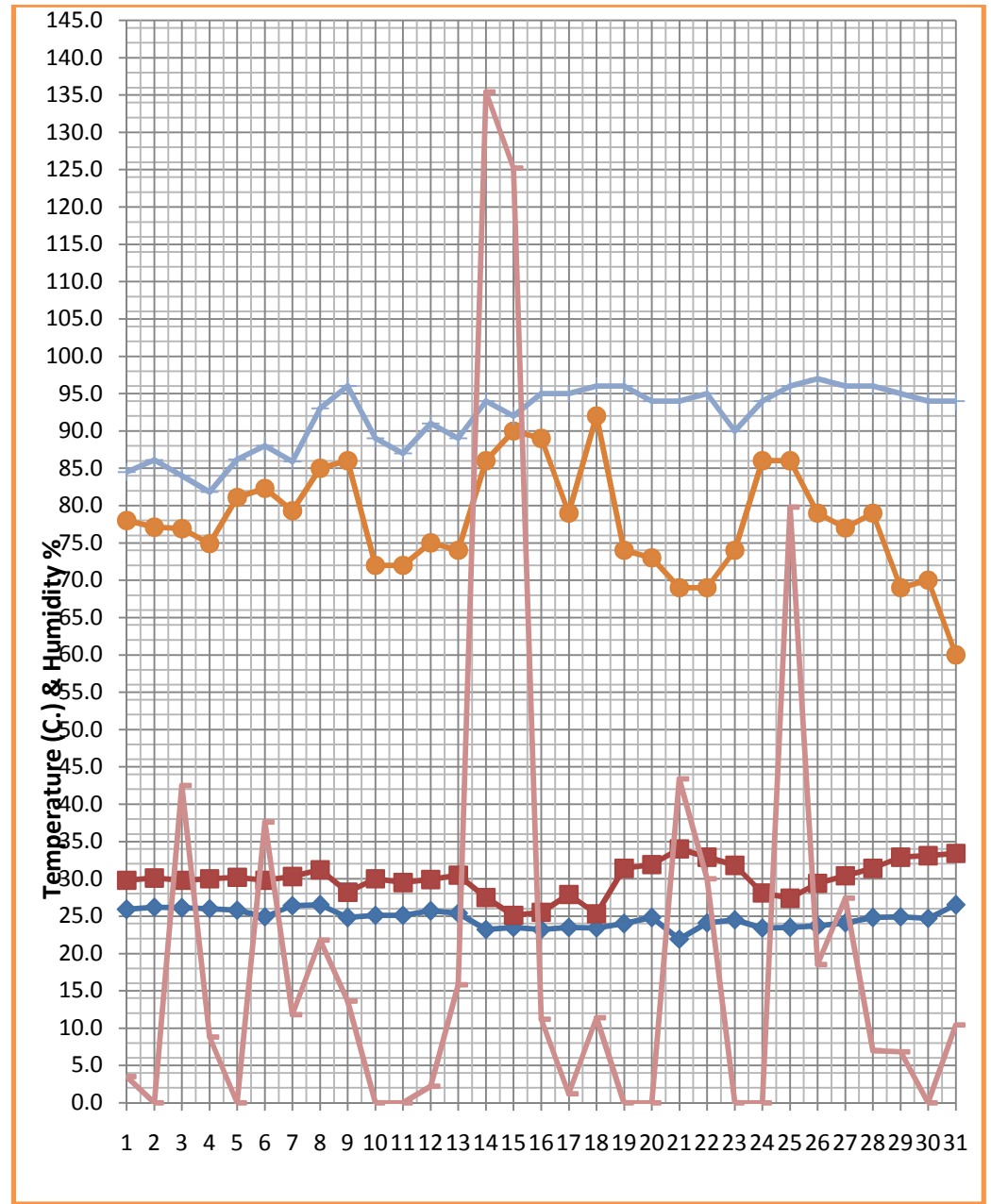

Status of Design Mixed and source approval

Sr. no.	Outgoing Letter NO.	Date of submission	Description	Approval letter no.	Date of approval
1	PDJHPL/PIU/CLO-179/2018/129	13.07.2018	Submission of Mix Design	LASA/Concessionaire/ DJ/IE/2018/0003	21.08.2018
	PDJHPL/PIU/CLO-179/2018/129	13.07.2018	M-15(PCC Work) with flyash		
	PDJHPL/PIU/CLO-179/2018/129	13.07.2018	M-25(RCC Work) with flyash		
	PDJHPL/PIU/CLO-179/2018/129	13.07.2018	M-30(RCC Work) with flyash		
	PDJHPL/PIU/CLO-179/2018/129	13.07.2018	M-35(RCC Work) with flyash		
	PDJHPL/PIU/CLO-179/2018/129	13.07.2018	M-35(Pile Work with flyash		
2	PDJHPL/PIU/CLO-179/2018/8/047	13.06.2018	Submission of Mix Design of Concrete from Ultratech & Mangalam Cement	LASA/Concessionaire/ DJ/IE/2018/0003	21.08.2018
	PDJHPL/PIU/CLO-179/2018/8/047	13.06.2018	M-35 RE Block (Ultratech & Mangalam cement)		
	PDJHPL/PIU/CLO-179/2018/8/047	13.06.2018	M-35 with flyash RE Block (Ultratech & Mangalam cement)		
	PDJHPL/PIU/CLO-179/2018/8/047	13.06.2018	M-15 PCC		
	PDJHPL/PIU/CLO-179/2018/8/047	13.06.2018	M-25 RCC		
	PDJHPL/PIU/CLO-179/2018/8/047	13.06.2018	M-30 RCC		
	PDJHPL/PIU/CLO-179/2018/8/047	13.06.2018	M-35 RCC		
	PDJHPL/PIU/CLO-179/2018/8/047	13.06.2018	M-35 Pile work		
3	PIL/CAMP/DJT/NHAI/2018-04/08	26.04.2018	Submission of Company profile & credential for the D.P. Wires	LASA/Concessionaire /Darah- Jhalawar/IE/2018/191	08.12.2018
4	PIL/CAMP/DJT/NHAI/2018-04/09	26.04.2018	Submission of Company profile & credential for the Shyam, Electrosteel and Premier Steel		
5	PDJHPL/NHAI/DJT/2018/019	12.03.2018	Submission of Company profile & credential for the Rashtriya Ispat Nigam Ltd (Vizag Steel),Nilkanth Steel Pvt.ltd. ,Steel authority of India limited (SAIL) ,Jindal steel & power limited ,Rashmi group ,Madhav Alloys Pvt.limited	LASA/Concessionaire/ DJ/IE/2018/17 and 58, 59 (10.09.2018)	30.08.2018
7	PIL/CAMP/DJP/N HAI/2018 -04 / 063	21.06.2018	Submission of construction material for testing.		
8	PIL/CAMP/DJP/N HAI/2018 -04 / 063	21.06.2018	Steel Dia 20mm JSW Steel (Fe-5.50D)		
10	PIL/CAMP/DJP/N HAI/2018 -04 / 063	21.06.2018	Steel - Dia 12,25 & 32mm SAIL (Fe-500D)		
10	PDJHPL/NHAI/DJT/2018/013	26.02.2018	Submission of Company profile & credential for the Birla Corporation Limited , Mangalam Cement Limited , Wonder cement Limited . Ultrtech cement Limited , Vadraj cement . Shree cement Limited	LASA/Concessionaire/ DJ/IE/2018/14	28.08.2018

Sr. no.	Outgoing Letter NO.	Date of submission	Description	Approval letter no.	Date of approval
11	PIL/CAMP/DJT/NHAI/2018-04/01	26.04.2018	Submission of Company profile & credential for the BASF India Ltd.for Admixture,Grout and joint Sealant , Unirock Chemicals (Admixture) , Tikitar Ltd. For Joint Sealant	LASA/Concessionaire/ DJ/IE/2018/016	30.08.2018
12	PDJHPL/NHAI/DJT/2018/020	22.03.2018	Submission of Company profile & credential for Admixture and curing compund ,Kunal conchem pvt.ltd.,National Chemicals Industries, Rheoplast technology pvt.ltd.,Molecules Conchem Pvt ltd.,Grout and joint Sealant ,STPLimited & Chembond Chemicals Ltd.		
13	PIL/CAMP/DJP/N HAI/2018 -04 / 063	21.06.2018	Adrnixture - PC 100R (Kunal Industries)		
14	PDJHPL/PIU/CLO-179/201 8/095	04.07.2018	DLC Flyash		
15	PDJHPL/PIU/CLO-179/201 8/095	04.07.2018	DLC without Flyash		
16	PIL/CAMP/DJP/N HAI/2018 -04 / 063	21.06.2018	GSB (Julmi PIL Crusher)		
18	PIL/CAMP/DJT/NHAI/2018-04/06	26.04.2018	Submission of Company profile & credential for the IOCL (Bitumen) ,HPCL (Bitumen) ,ESSAR (Bituman) , GP global (Emulsions) , HINCOL (Emulsions) Total oil India pvt ltd. (Emulsions)	LASA/Concessionaire/ DJ/IE/2018/020 Bitumen& 19 for Emulsion	31.08.208
19	PIL/CAMP/DJT/NHAI/2018-04/02	26.04.2018	Submission of Company profile & credential for the SGG spun pipes	LASA/Coessionaire/ Darah- Jhalawar/IE/2018/050	07.09.2018
20	PIL/CAMP/DJT/NHAI/2018-04/03	26.04.2018	Submission of Company profile & credential for the TIKIDAN Danosa India	LASA/Concessionaire /Darah- Jhalawar/IE/2018/212	14.12.2018
21	PIL/CAMP/DJT/NHAI/2018-04/04	26.04.2018	Submission of Company profile & credential for the KANTAFLEX India Pvt.ltd. (Elastomeric & Pot bearing)	LASA/Concessionaire /Darah- Jhalawar/IE/2018/206	13.12.2018
22	PIL/CAMP/DJT/NHAI/2018-04/05	26.04.2018	Submission of Company profile & credential for the Dynamic Prestress (I) Pvt Ltd.	LASA/Concessionaire /Darah- Jhalawar/IE/2018/195	08.12.2018
23	PIL/CAMP/DJT/NHAI/2018-04/07	26.04.2018	Submission of Company profile & credential for the Amitek Infra (Thermoplastic Road Marking Paint)	LASA/Concessionaire/ DJ/IE/2018/018	30.08.2018
24	PDJHPL/NHAI/DJT/2018/021	22.03.2018	Submission of Company profile & credential for the Nakoda spun pipes		
25	PDJHPL/NHAI/DJT/2018/022	22.03.2018	Submission of Laboratory profile & credentials for the Star wire INDIA Pvt., Third party, Hind Heat		
26	PDJHPL/PIU/CLO-179/201 8/047	21.06.2018	Submission of Gompany Profile & Gredential for source approval of Hercules Bridge Bearings & Bridge Expansion Joints	LASA/Concessionaire /Darah- Jhalawar/IE/2018/003	21.08.2018
27	PDJHPL/PIU/CLO-179/201 8/096	04.07.2018	Submission of Company Profile & Gredential for Arihant Prefab	LASA/Concessionaire/ Darah- Jhalawar/IE/2018/052	07.09.2018
28	PDJHPL/PIU/CLO-179/201 8/100	05.07.2018	Submission of Gompany profile & Gredeniir for M.E. Testing Laboratory	LASA/Concessionaire /Darah- Jhalawar/IE/2018/178	04.12.2018

Sr. no.	Outgoing Letter NO.	Date of submission	Description	Approval letter no.	Date of approval
29	PDJHPL/PIU/CLO-179/201 8/101	05.07.2018	Submission of Company Profile & Credential for Maruti Bitumin Pvt. Ltd	LASA/Concessionaire /Darah-Jhalawar/IE/2018/054	07.09.2018
30	PDJHPL/PRJ/TEC/CLO-179/2018/022	02.06.2018	Submission of profite,Credentials & Basic design report on RE walls	LASA/Concessionaire /Darah-Jhalawar/IE/2018/055	07.09.2018
31	PDJHPL/PIU/D/2018/032	16.04.2018	Submission of Quality assurance Plan		
32	PDJHPL/PIU/CLO-179/201 8/043	13.06.2018	Submission of Mix Design of Granular Sub-Base	LASA/Concessionaire /Darah-Jhalawar/IE/2018/155	28.11.2018
33	PDJHPL/PIU/CLO-179/201 8/044	13.06.2018	Submission of Summary of OGL test results		
34	PDJHPL/PIU/CLO-179/201 8/045	13.06.2018	Submission of Galibration Certificate of Batching Plant & Lab Equipments		
35	PDJHPL/PIU/CLO-179/201 8/046	13.06.2018	Submission of Third party test reports of the material related to the project		
36	PDJHPL/PIU/CLO-179/201 8/056	18.06.2018	Submission of Petrographic Test Report of Coarse Aggregate		
37	PDJHPL/PIU/CLO-179/201 8/108	06.07.2018	Submission of Borrow Area - 1,3,6,7,9,10,11,12,14,15,17,18,20,21,22,23, 24,26,27,29,30,31,32,33,34 & 35		
38	PDJHPL/PIU/CLO-179/2018/110	07.07.2018	Submission of Company Profile & Credential for Earthcon Systems Pvt. Ltd	LASA/Concessionaire /Darah-Jhalawar/IE/2018/049	06.09.2018
39	PDJHPL/PIU/CLO-179/2018/111	07.07.2018	Submission of Construction Design (Geogrid Reinforced Soil Wall)	LASA/Concessionaire /Darah-Jhalawar/IE/2018/063	15.09.2018
40	PDJHPL/PIU/CLO-179/2018/122	10.07.2018	Testing for C & O Value of soit samples of Borrow area No. 1 & 22		
41	PDJHPL/PIU/CLO-179/2018/129	13.07.2018	Submission of Mix-Design	LASA/Concessionaire/ Darah-Jhalawar/IE/2018/003	21.08.2018
42	PDJHPL/PIU/CLO-179/2018/133	16.07.2018	Submission of Trial Patch Report of GSB & DLC		
43	PDJHPL/IE/ICO-181/2018/241	28.08.2018	Submission of Company Profile & Credential OF Maruti Rub Plast Pvt. Ltd.	LASA/Concessionaire/ Darah-Jhalawar/IE/2018/088	15/10/2018
44	PDJHPL/IE/ICO-181/2018/242	28.08.2018	Submission of Company Profile & Credential Of Tar Products Pvt. Ltd.	LASA/Concessionaire/ Darah-Jhalawar/IE/2018/053	07/09/2018
45	PDJHPL/NHAI/DJT/013/2018	28.08.2018	Submission of Company Profile & Credentials for Birla Corporation, Mangalam Cement, Wonder Cement, Ultratech Cement, Vadraj Cement & Shree Cement.	LASA/Concessionaire/ Darah-Jhalawar/IE/2018/014	28/08/2018
46	PDJHPL/IE/ICO-181/2018/260	07.09.2018	Submission of Company Profile & Credential Of Sanfield (India) Ltd.	LASA/Concessionaire/ Darah-Jhalawar/IE/2018/072	28/09/2018
47	PDJHPL/IE/ICO-181/2018/286	18.09.2018	Submission of Company Profile & Credential for RAMA TMT Bars	LASA/Concessionaire/ Darah-Jhalawar/IE/2018/074	28/09/2018

Sr. no.	Outgoing Letter NO.	Date of submission	Description	Approval letter no.	Date of approval
48	PDJHPL/IE/ICO-181/2018/287	18.09.2018	Submission of Company Profile & Credential for SHYAM Steel	LASA/Concessionaire/ Darah- Jhalawar/IE/2018/073	28/09/2018
49	PDJHPL/IE/ICO-181/2018/318	29.09.2018	Submission of Company Profile & Credential of Sanfield (India) Ltd.-reg	LASA/Concessionaire /Darah- Jhalawar/IE/2018/078	03.10.2018
50	PDJHPL/IE/ICO-181/2018/348	09.10.2018	Submission of Company Profile & Credentials of Kataline paints.-reg	LASA/Concessionaire/ Darah- Jhalawar/IE/2018/091	15/10/2018
51	PDJHPL/IE/ICO-181/2018/353	10.10.2018	Submission of Third party testing of RE wall concrete block in km. 23+600-reg	LASA/Concessionaire /Darah- Jhalawar/IE/2018/130	13.11.2018
52	PDJHPL/IE/ICO-181/2018/362	12.10.2018	Submission of Company Profile & Credentials of PNT designs Pvt. Ltd.	LASA/Concessionaire /Darah- Jhalawar/IE/2018/126	13.11.2018
53	PDJHPL/IE/ICO-181/2018/367	13.10.2018	Submission of GSB Mix design for approvals	LASA/Concessionaire/ Darah -Jhalawar/IE/2018/111	29/10/2018
54	PDJHPL/IE/ICO-181/2018/381	18.10.2018	Submission of Filter media Mix-design – reg	LASA/Concessionaire /Darah- Jhalawar/IE/2018/217	13.11.2018
55	PDJHPL/IE/ICO-181/2018/408	26.10.2018	Submission of Company Profile and Credential of M/s Deevin Seismic Systems Pvt. Ltd. for Expansion Joints- reg	LASA/Concessionaire /Darah- Jhalawar/IE/2018/127	13.11.2018
56	PDJHPL/IE/ICO-181/2018/429	02/11/2018	Submission of DLC Mix Design Confirmatory Reports-reg	LASA/Concessionaire /Darah- Jhalawar/IE/2018/163	03.12.2018
57	PDJHPL/IE/ICO-181/2018/450	17/11/2018	Submission of Company profile & Credetials of M/s Deevin Seismic Systems Pvt. Ltd. for Expansion joints - reg	LASA/Concessionaire /Darah- Jhalawar/IE/2018/199	12.12.2018
58	PDJHPL/IE/ICO-181/2018/451	17/11/2018	Submission of third party test report of construction materials-reg		
59	PDJHPL/IE/ICO-181/2018/452	17/11/2018	Submission of Company profile & Credential of JK Lakshmi Cement Ltd-reg	LASA/Concessionaire/ Darah -Jhalawar/IE/2018/148	26/11/2018
60	PDJHPL/IE/ICO-181/2018/453	17/11/2018	Submission of company Profile & Credentials of Supreme Bitumen India Pvt. Ltd.	LASA/Concessionaire /Darah- Jhalawar/IE/2018/162	03.12.2018
61	PDJHPL/IE/ICO-181/2018/454	17/11/2018	Resubmission of Company Profile & Credentials of M/s Hind Heat Treatment & Testing House-reg	LASA/Concessionaire /Darah- Jhalawar/IE/2018/158	30.11.2018
62	PDJHPL/IE/ICO-181/2018/455	17/11/2018	Submission of Company Profile & Credentials of M/s Yash Enterprises-reg	LASA/Concessionaire /Darah- Jhalawar/IE/2018/177	04.12.2018
63	PDJHPL/IE/ICO-181/2018/460	20/11/2018	Submission of Company Profile & Credentials of M/s Electrotherm India Ltd. -	LASA/Concessionaire /Darah- Jhalawar/IE/2018/190	08.12.2018
64	PDJHPL/IE/ICO-181/2018/461	20/11/2018	Submission of Mix Design of WMM-reg	LASA/Concessionaire/ Darah -Jhalawar/IE/2018/152	27/11/2018
66	PDJHPL/IE/ICO-181/2018/473	22/11/2018	Submission of Concrete Mix Design Done only with Wonder & Ultratech Cement-reg	LASA/Concessionaire /Darah- Jhalawar/IE/2018/211	15.12.2018
67	PDJHPL/IE/ICO-181/2018/475	22/11/2018	Submission of Concrete Mix Design Using Fly ash with Wonder & Ultratech Cements-reg		

Sr. no.	Outgoing Letter NO.	Date of submission	Description	Approval letter no.	Date of approval
68	PDJHPL/IE/ICO-181/2018/479	23/11/2018	Submission of PQC M-40 Design Using Fly ash with Ultratech Cement-reg	LASA/Concessionaire /Darah- Jhalawar/IE/2018/176	04.12.2018
69	PDJHPL/IE/ICO-181/2018/480	23/11/2018	Submission of Company Profile & Credentials of M/s Kunal Conchem Pvt. Ltd.-reg	LASA/Concessionaire/ Darah -Jhalawar/IE/2018/147	26/11/2018
70	PDJHPL/IE/ICO-181/2018/510	30/11/2018	Submission of PQC M-40 Design with Ultratech Cement.		
71	PDJHPL/IE/ICO-181/2018/511	30/11/2018	Submission of Company Profile & Credentials of M/s. Normat India Pvt.Ltd	LASA/Concessionaire/ Darah -Jhalawar/IE/2018/207	13/12/2018
72	PDJHPL/IE/ICO-181/2018/521	03/12/2018	Submission of Julmi Crusher Aggregate Test Reports-reg	LASA/Concessionaire/ Darah- Jhalawar/IE/2018/196	10/12/2018
73	PDJHPL/IE/ICO-181/2018/522	03/12/2018	Submission of Fine Aggregate Test Report of Kalisindh River-reg	LASA/Concessionaire/ Darah- Jhalawar/IE/2018/197	10/12/2018
74	PDJHPL/IC/ICO-181/2018/542	08/12/2018	Submission of company profile & credential of M/s HI-TECH Engineering Solutions - reg		
75	PDJHPL/IC/ICO-181/2018/599	21/12/2018	Submission of Test Report of Spun pipes for NP-4 pipe - reg	LASA/Concessionaire/ Darah- Jhalawar/IE/2018/226	24/12/2018
76	PDJHPL/IC/ICO-181/2018/620	31/12/2018	Submission of Inspection Report of Elastomeric Bearing Testing (KANTAFLEX) - reg	LASA/Concessionaire /Darah- Jhalawar/IE/2018/247	04.01.2019
77	PDJHPL/IC/ICO-181/2018/626	02/01/2019	Submission of Chemical Composition Test Report of Steel.	LASA/Concessionaire/ Darah- Jhalawar/IE/2018/288	24/01/2019
78	PDJHPL/IC/ICO-181/2019/638	05/01/2019	Submission of PQC (M-40) Mix Design with Ultratech Cement.	LASA/Concessionaire/ Darah- Jhalawar/IE/2018/252	11/01/2019
79	PDJHPL/IC/ICO-181/2019/639	05/01/2019	Submission of PQC (M-40) Mix Design using Flyash with Ultratech Cement.	LASA/Concessionaire/ Darah- Jhalawar/IE/2018/250	10/01/2019
80	PDJHPL/IC/ICO-181/2019/643	07/01/2019	Submission of Company Profile and Credentials of Molecule Conchem Pvt.Ltd	LASA/Concessionaire/ Darah- Jhalawar/IE/2018/273	21.01.2019
81	PDJHPL/IC/ICO-181/2019/653	10/01/2019	Submission of Test Report of T.M.T Bars from Electrotherm (India) Ltd.	LASA/Concessionaire/ Darah- Jhalawar/IE/2019/297	04/02/2019
82	PDJHPL/IC/ICO-181/2019/665	15/01/2019	Submission of Third Party Test Report of Reinforcement Steel (Hind Heat Treatment)	LASA/Concessionaire/ Darah- Jhalawar/IE/2019/292	28/01/2019
83	PDJHPL/IC/ICO-181/2019/666	15/01/2019	Review of Mix Design of PQC (M-40) with Ultratech Cement & Unirock Plasticizers.		
84	PDJHPL/IC/ICO-181/2019/672	16/01/2019	Review of Mix Design of PQC (M-40) with Ultratech Cement , Flyash & Unirock Plasticizers.		
85	PDJHPL/IC/ICO-181/2019/685	21/01/2019	Submission of Company Profile and Credentials of Choksey Chemicals Pvt.Ltd.	LASA/Concessionaire/ Darah- Jhalawar/IE/2019/289	28/01/2019
86	PDJHPL/IC/ICO-181/2019/686	21/01/2019	Submission of Company Profile and Credentials of J.K Cement Ltd.	LASA/Concessionaire/ Darah- Jhalawar/IE/2019/290	28/01/2019

Sr. no.	Outgoing Letter NO.	Date of submission	Description	Approval letter no.	Date of approval
87	PDJHPL/IC/ICO-181/2019/713	31/01/2019	Submission of Test Report of POT/ PTFE Bearings for Flyover+Major Bridge 47+650 to 48+150 (Dynamic Prestress Pvt. Ltd).	LASA/Concessionaire/ Darah- Jhalawar/IE/2019/304	06/02/2019
88	PDJHPL/IC/ICO-181/2019/732	06/02/2019	Submission of PQC Trial patch Report from Ch.28+400 to 28+147(LHS) - reg		
89	PDJHPL/IC/ICO-181/2019/753	12/02/2019	Submission of Company Profile & Credentials of Ooms Avenhorn Holding India Pvt. Ltd. & Ooms Polymer Modified Bitumen Pvt. Ltd.-reg	LASA/Concessionaire/ Darah- Jhalawar/IE/2019/307	18/02/2019
90	PDJHPL/IC/ICO-181/2019/761	14/02/2019	Submission of Company Profile & Credential of Unirock Chemicals Pvt. Ltd.-reg	LASA/Concessionaire/ Darah- Jhalawar/IE/2019/308	18/02/2019
91	PDJHPL/IC/ICO-181/2019/788	20/02/2019	Submission of Company Profile & Credential of MSP Group for procurement of Dowel Bars - reg		
92	PDJHPL/IC/ICO-181/2019/798	25/02/2019	Submission of Company Profile & Credential of M/s Sika India - reg	LASA/NHAI/Darah- Jhalawar/IE/2019/350	16.03.2019
93	PDJHPL/IC/ICO-181/2019/804	26/02/2019	Submission of Company Profile & Credential of M/s STP Ltd - reg	LASA/NHAI/Darah- Jhalawar/IE/2019/351	16.03.2019
94	PDJHPL/IC/ICO-181/2019/812	28/02/2019	Submission of Company Profile & Credential of MSP steel & Power Ltd - reg.		
95	PDJHPL/IC/ICO-181/2019/833	07/03/2019	Submission of Company Profile & Credential of Chembond Chemicals - reg	LASA/Concessionaire/ Darah- Jhalawar/IE/2019/352	16.03.2019
96	PDJHPL/IC/ICO-181/2019/962	23/04/2019	Submission of Company Profile & Credential of Fortune Ltd - reg		
97	PDJHPL/IC/ICO-181/2019/967	25/04/2019	Submission of Company Profile & Credential of Balajee Loha Ltd - reg		
98	PDJHPL/IC/ICO-181/2019/1018	09/05/2019	Submission of Company Profile & Credential of Essar Steel - reg		
99	PDJHPL/IC/ICO-181/2019/1019	09/05/2019	Submission of Company Profile & Credential of Bostik Pvt Ltd - reg	LASA/Concessionaire/ Darah- Jhalawar/IE/2019/415	16/05/2019
100	PDJHPL/IC/ICO-181/2019/1031	11/05/2019	Submission of Methodology of Pile Load Test of Routine Pile @ 57+127 (MJB)		
101	PDJHPL/IC/ICO-181/2019/1048	16/05/2019	Submission of Methodology of Pile Load Test of Routine Pile @ 36+070 (MJB)	LASA/Concessionaire/ Darah- Jhalawar/IE/2019/429	24/05/2019
102	PDJHPL/IC/ICO-181/2019/1074	25/05/2019	Submission of Plate Load Test Report Conducted at 36+070 (MJB) & 58+128 (Flyover).		
103	PDJHPL/IC/ICO-181/2019/1083	28/05/2019	Submission of Initial Load Test Report Conducted on Test Pile .		
104	PDJHPL/IC/ICO-181/2019/1088	30/05/2019	Submission of Company Profile & Credential of Nuvoco Vistas Corp. Ltd - reg		
105	PDJHPL/IC/ICO-181/2019/1098	03/06/2019	Submission of Kerb (M-20) with Ultratech Cement without Flyash.	LASA/Concessionaire/ Darah- Jhalawar/IE/2019/446	10/06/2019
106	PDJHPL/IC/ICO-181/2019/1099	03/06/2019	Submission of SPT Test Report for Ch.36+070 (MJB)		
107	PDJHPL/IC/ICO-181/2019/1100	03/06/2019	Submission of Bore Log Test Report @ 36+070 (MJB) & 58+128 (Flyover).		
108	PDJHPL/IC/ICO-181/2019/1189	30/06/2019	Submission of Company Profile & Credential of STECOL (Essar TMT Brand)		

Status of submitted Drawings

S.No	Type of Structure	Scope in Nos	No. of Drawing Submitted	Vide Letter No.	Date	Proof Check	Remarks
1	Pipe Culvert	16	R0-16 Nos.	PDJHPL/PIU/D/016/2018	27.02.2018	NIL	
				PDJHPL/PIU/CLO-179/2018/146	23.07.2018	NIL	
			R1-8 Nos.	PDJHPL/PIU/CLO-179/2018/146	23.07.2018	NIL	Approved
2	Box Culvert	21	R0-20 Nos.	PDJHPL/PIU/D/016/2018	27.02.2018	NIL	
				PDJHPL/PIU/CLO-179/2018/093	04.07.2018	NIL	
				PDJHPL/PIU/CLO-179/2018/041	12.06.2018	NIL	
				PDJHPL/PIU/CLO-179/2018/037	07.06.2018	NIL	
			R1-20 Nos.	PDJHPL/PIU/CLO-179/2018/093	04.07.2018	NIL	
				PDJHPL/PIU/CLO-179/2018/137	18.07.2018	NIL	
				PDJHPL/PIU/CLO-179/2018/138	18.07.2018	NIL	
				PDJHPL/PIU/CLO-179/2018/228	22.08.2018	NIL	
				PDJHPL/PIU/CLO-179/2018/388	18.10.2018	NIL	
				PDJHPL/PIU/CLO-179/2018/463	20.11.2018	NIL	Approved
3	Minor Bridge	11	R0-10 Nos.	PDJHPL/PIU/D/016/2018	27.02.2018	NIL	
				PDJHPL/PIU/CLO-179/2018/146	23.07.2018	NIL	
				PDJHPL/PIU/CLO-189/2018/191	09.08.2018	NIL	
			R1-05 Nos	PDJHPL/PIU/CLO-179/2018/037	07.06.2018	NIL	
				PDJHPL/IE/ICO-181/2018/317	29.09.2018	NIL	
			Compliance	PDJHPL/IE/ICO-181/2018/487	23.11.2018	NIL	
				PDJHPL/IE/ICO-181/2018/488	26.11.2018	NIL	
				PDJHPL/IC/ICO-181/2018/562	11.12.2018	NIL	
				PDJHPL/IC/ICO-181/2018/582	17.12.2018	NIL	
			R1 – 01 Nos	PDJHPL/IC/ICO-181/2018/816	01.03.2019		
4	Major Bridge	2	R0-02 Nos	PDJHPL/PIU/D/034/2018	19.04.2018	NIL	
			R1-03 Nos	PDJHPL/PIU/CLO-179/2018/037 01 Nos. (Letter -119 date- 09.07.2018) (Proof Checked)	07.06.2018	1 set	
				PDJHPL/PIU/CLO-179/2018/072	25.06.2018		Approved
				PDJHPL/IE/ICO-181/2018/272	12.09.2018		Approved
				PDJHPL/HO/DJT/IE/578/2018	15.12.2018	1 set	Approved
5	Elevated Road	1	R1-01 Nos	PDJHPL/PIU/CLO-179/2018/037 01 Nos. (Letter -119 date- 09.07.2018) (Proof Checked)	07.06.2018	1 set	Approved

S.No	Type of Structure	Scope in Nos	No. of Drawing Submitted	Vide Letter No.	Date	Proof Check	Remarks
6	VUP	9	R0-09 Nos	PDJHPL/PIU/D/018/2018	12.03.2018		
				PDJHPL/PIU/D/014/2018	27.02.2018		
				Letter No- 041 (IIT Certified Copy)	12.06.2018	1 set	
			R1-06 Nos	Letter No- 041 (IIT Certified Copy) (Letter -158 date- 28.07.2018)	12.06.2018	1 set	
				(Letter -188 date- 08.08.2018)	08.08.2018		Approved (05 Nos)
			R2-04 Nos.	PDJHPL/IC/ICO-181/583	17.12.2018		
				PDJHPL/IC/ICO-181/632	03.01.2019		
7	LVUP	13	R0-13 Nos	PDJHPL/PIU/D/016/2018	27.02.2018	NIL	
				PDJHPL/PIU/CLO-179/2018/067	22.06.2018	NIL	Approved (06 Nos)
			R1-06 Nos	PDJHPL/PIU/CLO-179/2018/067	22.06.2018	NIL	
				PDJHPL/IC/ICO-181/2019/811	28/02/2019		
8	FlyOver	3	R0-03 Nos	PDJHPL/PIU/D/034/2018	19.04.2018	1 set	
			R1-03 Nos	PDJHPL/PIU/CLO-179/2018/115	09.07.2018	NIL	
			R2-03 Nos	PDJHPL/IC/ICO-181/2018/431	03.11.2018	2 set	
9	ROB	1	R1-01 Nos	PDJHPL/PIU/CLO-179/2018/118 01 Nos. (Letter-118 date- 09.07.2018) Proof Checked)	09.07.2018	1 set	Approved
				PDJHPL/IC/ICO-181/2018/550	10.12.2018	2 set	
10	RUB	1	R1-01 Nos	PDJHPL/PIU/TEC/CLO- 179/2018/019 Hard Copy of Trecing Paper Drawing	31.05.2018	1 set	Approved
	Total	78					
1	Plan & Profile	48.88 Km	R0-01 Nos	PDJHPL/PIU/CLO-179/2018/106	06.07.2018	NIL	
				PDJHPL/IC/ICO-181/2018/364	12.10.2018	NIL	
			R1-01 Nos	PDJHPL/IC/ICO-181/2018/474	22.11.2018	NIL	
				PDJHPL/HO/DJT/IE/001/2019	07.01.2019	NIL	
				PDJHPL/HO/DJT/IE/007/2019	19.01.2019		Approved upto 48.88 Km
2	TOLL PLAZA		R0-01 Nos	PDJHPL/IC/ICO-181/2018/316	29.09.2018		Approved
3	POT/PTFE Bearing		46+950, 50+095, 58+128	PDJHPL/IC/ICO-181/2018/430	03.11.2018		Approved
4	Pavement			PDJHPL/HO/DJT/IE/008/2019	19.01.2019		Approved

S.No	Type of Structure	Scope in Nos	No. of Drawing Submitted	Vide Letter No.	Date	Proof Check	Remarks
	Design						
5	RE wall		VUP (12+125) & 12+450 (LVUP)	PDJHPL/IC/ICO-181/2018/658	12/01/2019		
			LVUP (15+725)	PDJHPL/PIU/CLO-189/2018/200	11/08/18		
			LVUP (17+353)	PDJHPL/PIU/CLO-189/2018/201	11/08/18		
			VUP (19+970)	PDJHPL/IC/ICO-181/2018/659	12/01/2019		
			LVUP (21+183)	PDJHPL/IC/ICO-181/2018/660	12/01/2019		
			LVUP (23+065)	PDJHPL/IC/ICO-181/2018/661	12/01/2019		
			LVUP (23+687)	PDJHPL/IC/ICO-181/2018/662	12/01/2019		
			LVUP (24+547) & VUP (25+100)	PDJHPL/PIU/CLO-189/2018/202	11/08/18		
			LVUP (27+029)	PDJHPL/PIU/CLO-189/2018/203	11/08/18		
			LVUP (37+050)	PDJHPL/PIU/CLO-189/2018/204	11/08/18		
			LVUP (38+545)	PDJHPL/PIU/CLO-189/2018/205	11/08/18		
			VUP (49+330) (R0)	PDJHPL/IE/ICO-181/2018/534	07/12/2018		Approved
			VUP (49+330) (R1)	PDJHPL/IE/ICO-181/2018/603	24/12/2018		
			VUP (49+330) (R2)	PDJHPL/IC/ICO-181/2019/760	14/02/2019		
			Flyover (50+099) (R0)	PDJHPL/IE/ICO-181/2018/535	07/12/2018		Approved
			Flyover (50+099) (R1)	PDJHPL/IE/ICO-181/2018/602	24/12/2018		
			Flyover (50+099) (R2)	PDJHPL/IC/ICO-181/2019/759	14/02/2019		
			VUP (41+102) & LVUP (41+465) (R0)	PDJHPL/IE/ICO-181/2018/536	07/12/2018		Approved
			VUP (41+102) & LVUP (41+465) (R1)	PDJHPL/IC/ICO-181/2019/719	01/02/2019		
			LVUP (42+263) (R0)	PDJHPL/IE/ICO-181/2018/537	07/12/2018		Approved
			LVUP (42+263) (R1)	PDJHPL/IC/ICO-181/2019/720			
			Design & Drawing for Sandy Soil	PDJHPL/IE/ICO-181/2018/548	10/12/2018		

Mobilization of Manpower

Name of the Employee		Designation		Department
Amit	Garg	General Manager		Technical
Milind	Pande	Project Incharge		Technical
Atul Kumar	Mishra	Project Manager		Technical
Shubhash	Kumar	Sr.Manager		Mechanical
Balram Singh	Shekhawat	Manager		Liasion
Bhagwan	Jha	Manager		Purchase
Rajesh	Chaturvedi	Dy. Project Manager		Technical
Ranjay Kumar	Anju	Dy. Project Manager		Planning & Billing
Devesh	Pandey	Dy. Project Manager		QA/QC
Ramesh Chandra	Barad	Dy. Manager (HR & Admin)		HR & Admin
Mahesh	Pandey	Dy. Project Manager		Highway
Sajjan Lal	Sharma	Dy. Project Manager		Structure
Bal Krishna	Rath	Dy. Project Manager		Structure
Kuldeep singh	Shivnathsingh	Sr.Surveyor		Survey
Ravi Kishore Pandey	Dinanath Pandey	Sr.Accountant		Finance & Accounts
Dayanand	Prakash	Engineer		Health & Safety
Rajesh	Raval	Material Engineer		QA/QC
Brijkishor	Ramsewak	Engineer		QA/QC
HR & ADMIN DEPARTMENT				
Sr. Executive		2	Nos	HR & Admin
Sr.Officer(S & V)		1	Nos	HR & Admin
Executive		2	Nos	HR & Admin
Jr.Executive		2	Nos	HR & Admin
Security violation		2	Nos	HR & Admin
Office Boy		6	Nos	HR & Admin
PLANNING & BILLING DEPARTMENT				
Sr.Engineer		2	Nos	Planning & Billing
Engineer		1	Nos	Planning & Billing
Asst. Engineer		2	Nos	Planning & Billing
QA/QC DEPARTMENT				
Asst.Manager		1	Nos	QA/QC
Lab Asst.		1	Nos	QA/QC
Sr.Lab Technician		2	Nos	QA/QC
Lab Technician		7	Nos	QA/QC
Jr.Lab Technician		1	Nos	QA/QC
Engineer		3	Nos	QA/QC
Jr.Engineer		3	Nos	QA/QC
HIGHWAY DEPARTMENT				
Sr. Engineer		3	Nos	Highway
Engineer		3	Nos	Highway
Asst. Engineer		8	Nos	Highway
Jr.Engineer		6	Nos	Highway
Engineer Trainee		2	Nos	Highway
Jr. Supervisor		1	Nos	Highway
Supervisor		11	Nos	Highway
STRUCTURE DEPARTMENT				
Sr. Engineer		5	Nos	Structure
Engineer		6	Nos	Structure

Name of the Employee		Designation		Department
Asst. Engineer	4	Nos		Structure
Jr.Engineer	4	Nos		Structure
Engineer Trainee	1	Nos		Structure
Sr.Supervisor	6	Nos		Structure
Supervisor	3	Nos		Structure
Jr.Supervisor	3	Nos		Structure
SURVEY DEPARTMENT				
Sr. Surveyor	1	Nos		Survey
Surveyor	10	Nos		Survey
Jr.Surveyor	4	Nos		Survey
STORE DEPARTMENT				
Jr. Executive	5	Nos		Store
Executive	8	Nos		Store
WEIGH BRIDGE				
Jr.Executive	13	Nos		Weigh Bridge
PURCHASE DEPARTMENT				
Dy.Manager	1	Nos		Purchase
Sr.Executive	1	Nos		Purchase
Executive	1	Nos		Purchase
HEALTH & SAFETY DEPARTMENT				
Sr.Executive	1	Nos		Health & Safety
Engineer	1	Nos		Health & Safety
Executive	1	Nos		Health & Safety
IT DEPARTMENT				
Sr.Executive	1			IT
Executive	1			IT
MECHANICAL DEPARTMENT				
Sr.Supervisor	1	Nos		Mechanical
Sr. Engineer	3	Nos		Mechanical
Engineer	1	Nos		Mechanical
Asst. Engineer	3	Nos		Mechanical
Executive	1	Nos		Mechanical
Asst. Mechanic	3	Nos		Mechanical
Fitter	1	Nos		Mechanical
Tyre Fitter	4	Nos		Mechanical
Jr.Engineer	2	Nos		Mechanical
Jr.Executive	3	Nos		Mechanical
Engineer Trainee	1	Nos		Mechanical
Supervisor	6	Nos		Mechanical
Driver	69	Nos		Mechanical
Computer Operator	1	Nos		Mechanical
Operator / Helper / Mechanic	105	Nos		Mechanical
SPV DEPARTMENT				
Dy.Manager	1	Nos		SPV
Sr.Executive	1	Nos		SPV
Executive	1	Nos		SPV

Mobilization of Resources (Plant and Machineries)

S. No	Name of Machinery	Nos of Equipments	Remarks
1	Excavator	16	
2	Hywa / Tipper	69	
3	Soil Compactor	8	
4	Dozer	0	
5	Water Tanker	17	
6	Diesel Dispenser	4	
7	Grader	5	
8	Loader	7	
9	Back Hoe	4	
10	Transit Mixer	16	
11	Crusher	2	
12	Concrete Batching Plant	4	
13	Weigh Bridge	6	
14	WMM Plant	1	
15	Hydra Crane	5	
16	Hot Mix Plant	1	
17	Concrete Pump	1	
18	Sand Classifier	2	
19	Tractor	5	
20	Tower Light	8	
21	DG Set	15	
22	Light Vehicle	35	
23	Trailer	5	
24	JCB	2	
25	Concrete Boom Placer	1	
26	Tandem Roller	4	
27	Baby Tandem Roller	2	
28	Mobile Service Van	1	
29	DLC Paver	1	
30	Automatic PQC Paver	1	
31	Kerb Paver	2	
32	Chilling plant	1	
	TOTAL	250	

Site Progress Photo



CUTTING WORK OF PQC



LAYING WORK OF PQC





MNB SLAB (3 CELL) @ KM. 49+775



CASTING OF PIER CAP P16 RHS @ KM. 47+830



SLAB CASTING OF ELEVATED @ KM.47+830



PILE CAP P-11 (LHS) OF MJB @ Km. 36+070

PHOTOGRAPHS FOR MAINTENANCE WORKS OF EXISTING ROAD



11+850



11+850







DIVERSION REPAIRING WORK @ CH: 23+675



DIVERSION REPAIRING WORK @ CH: 25+ 100

Project:-Construction of 4-lane Road on NH-12 (New NH-52) from Km 299.000 to 346.540 (Design Chainage from 9.860 to 58.740) (Darah-Jhalawar-Teendhar section) in the State of Rajasthan under NHDP Phase-III on Hybrid Annuity Project(Length 48.880 Km.) -Pa

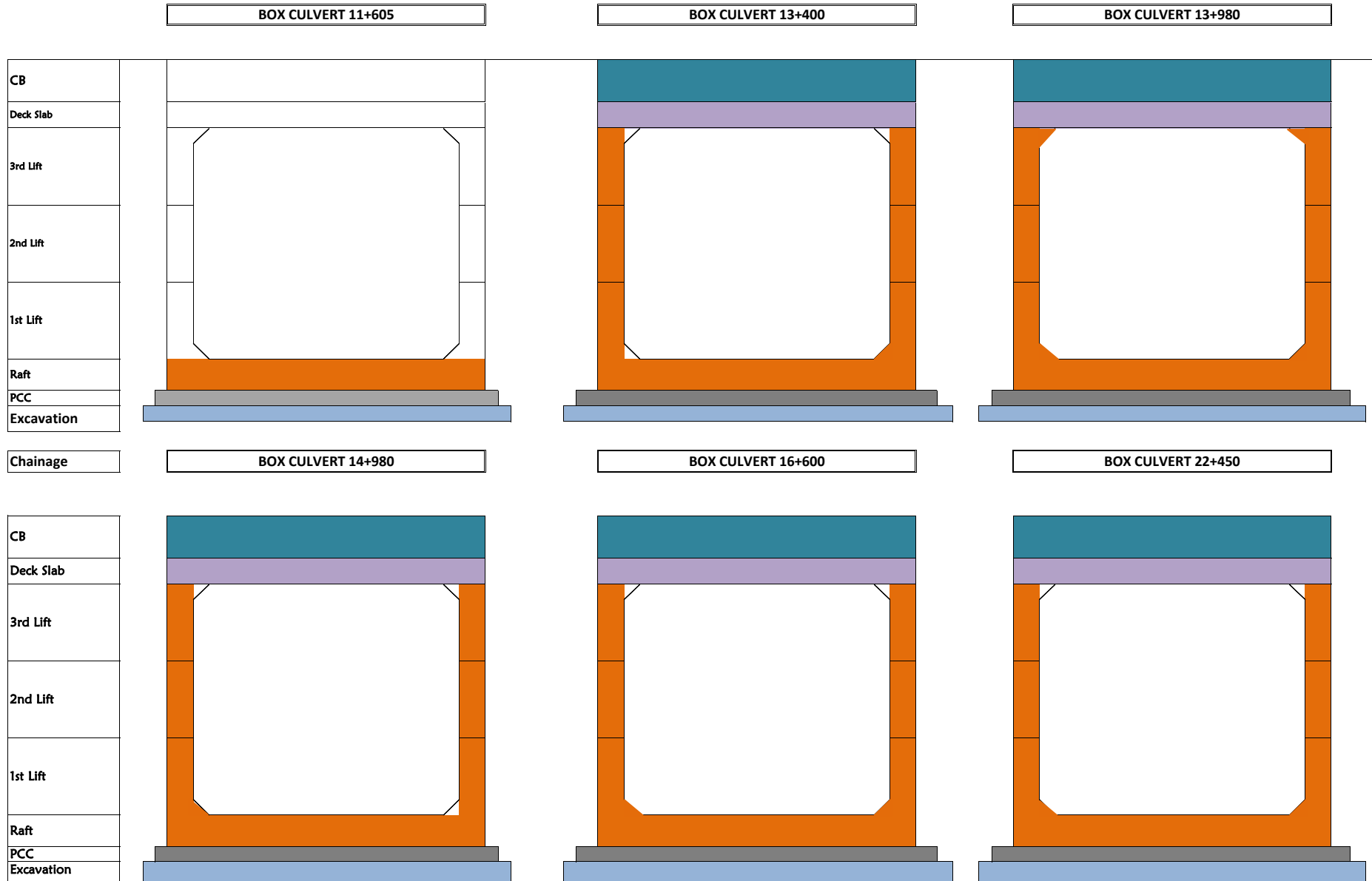

Project:-Construction of 4-lane Road on NH-12 (New NH-52) from Km 299.000 to 346.540 (Design Chainage from 9.860 to 58.740) (Darah-Jhalawar-Teendhar section) in the State of Rajasthan under NHDP Phase-III on Hybrid Annuity Project(Length 48.880 Km.) -Pa



Project:-Construction of 4-lane Road on NH-12 (New NH-52) from Km 299.000 to 346.540 (Design Chainage from 9.860 to 58.740) (Darah-Jhalawar-Teendhar section) in the State of Rajasthan under NHDP Phase-III on Hybrid Annuity Project(Length 48.880 Km.) -Pa

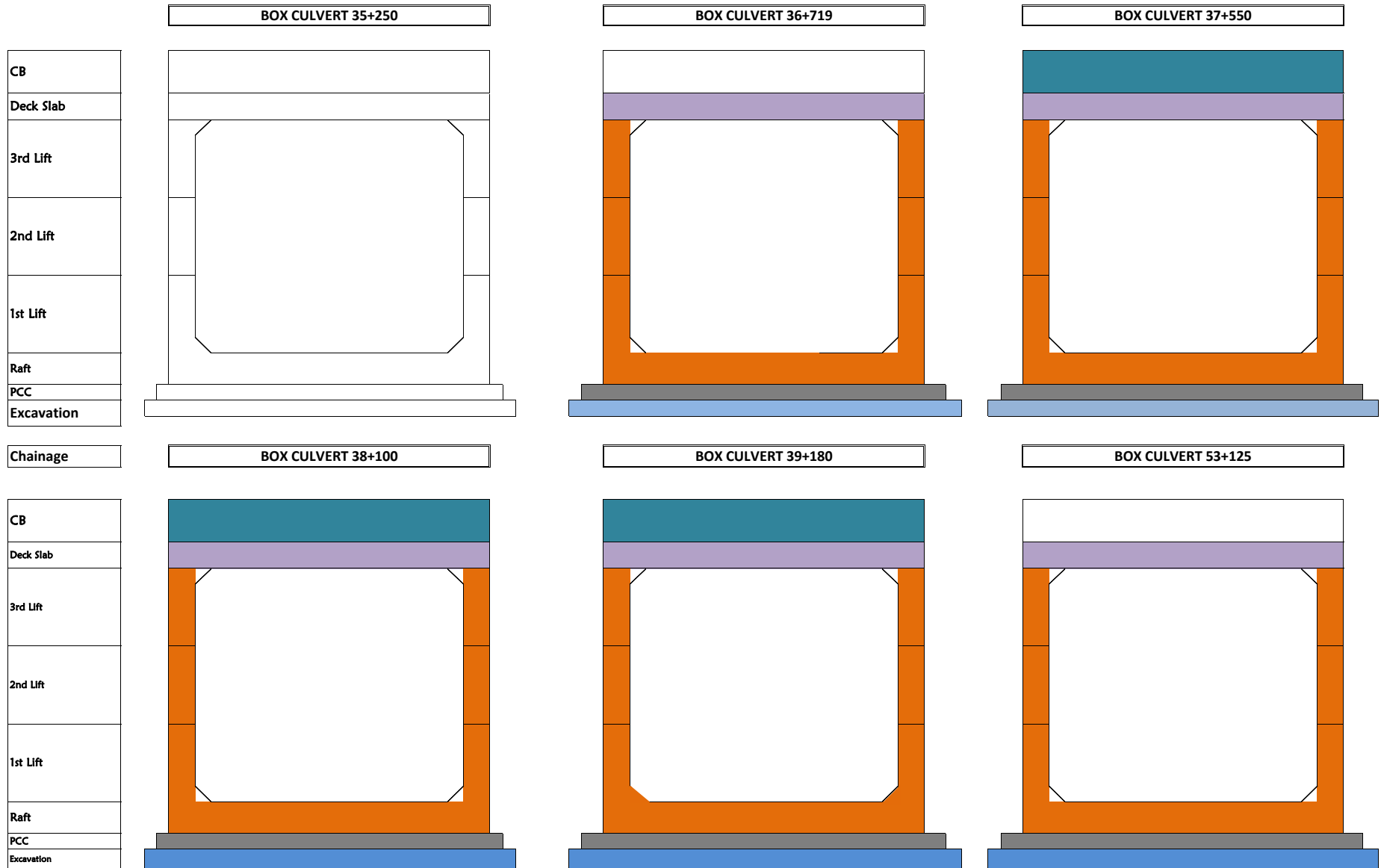

Project:-Construction of 4-lane Road on NH-12 (New NH-52) from Km 299.000 to 346.540 (Design Chainage from 9.860 to 58.740) (Darah-Jhalawar-Teendhar section) in the State of Rajasthan under NHDP Phase-III on Hybrid Annuity Project(Length 48.880 Km.) -Pa

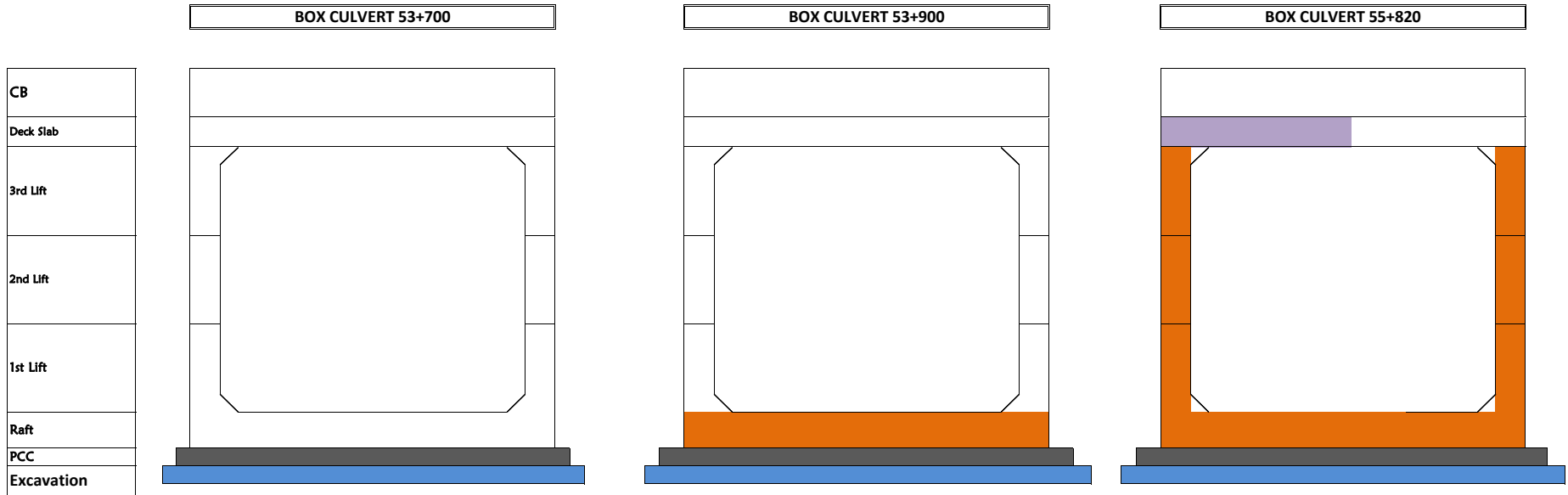

Additional / SR

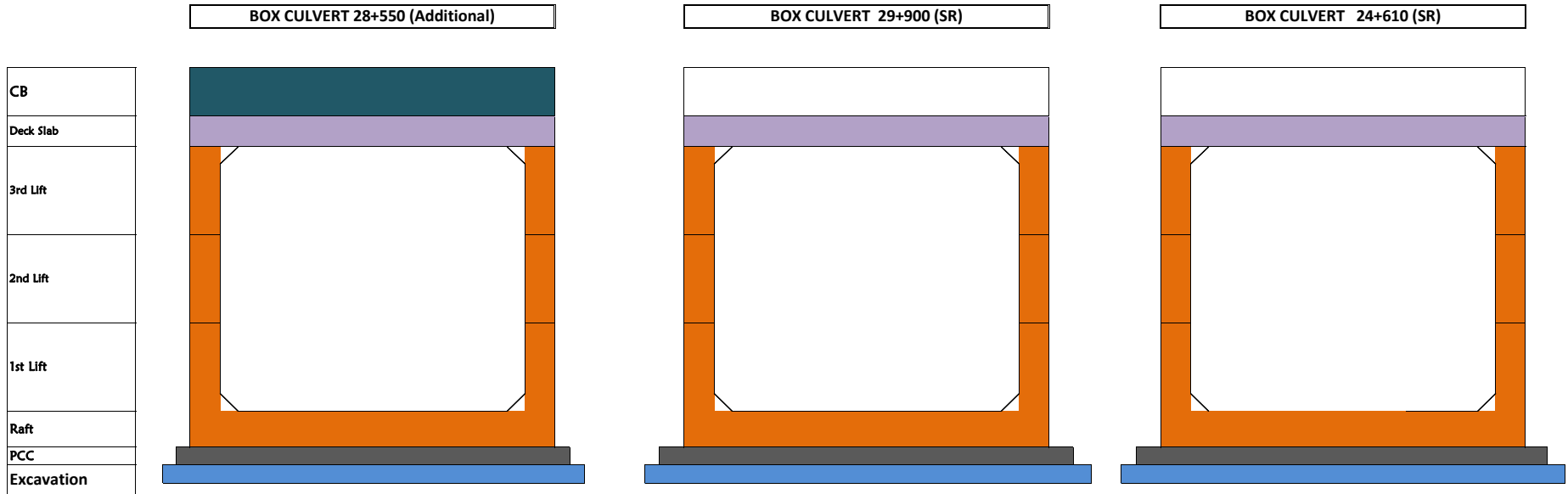

MINOR BRIDGE AT KM. 16+060 (Main Carriage Way) RHS

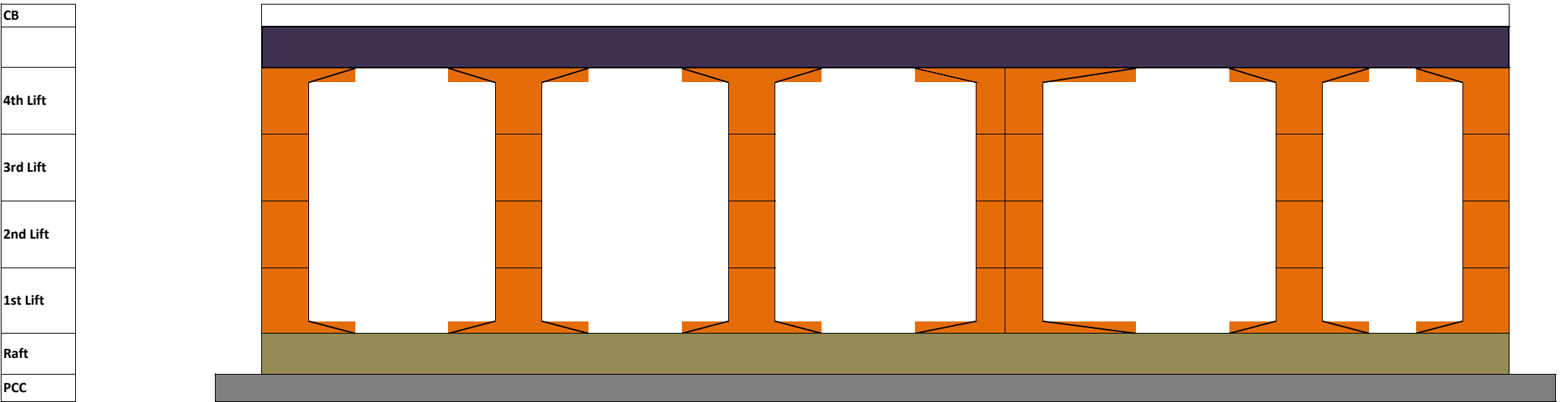

MINOR BRIDGE AT KM. 16+060 (Main Carriage Way) LHS

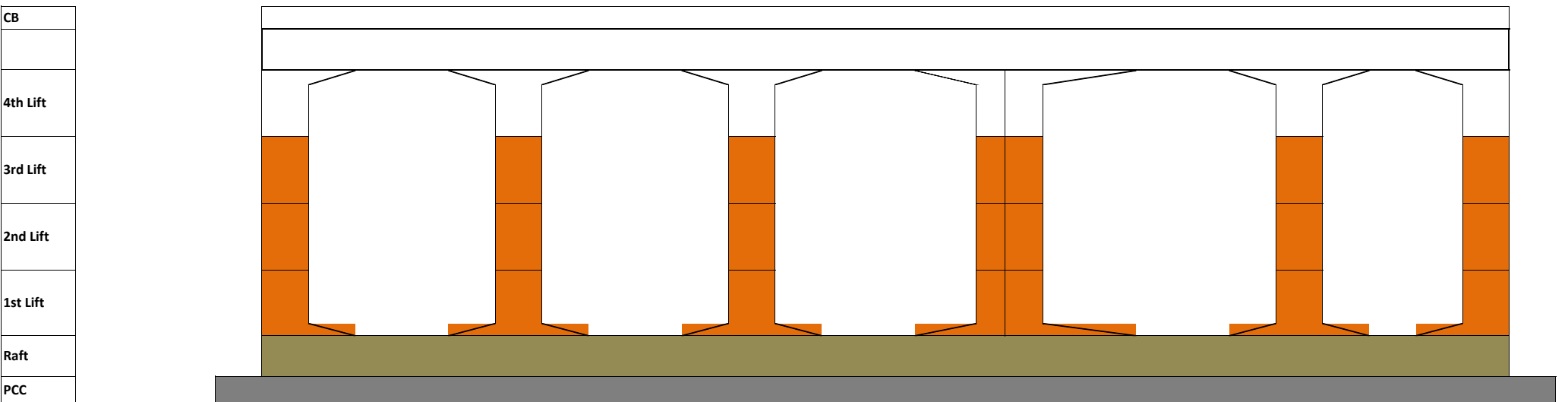

MINOR BRIDGE AT KM. 16+060 (Service Road) RHS

CB
4th Lift
3rd Lift
2nd Lift
1st Lift
Raft
PCC

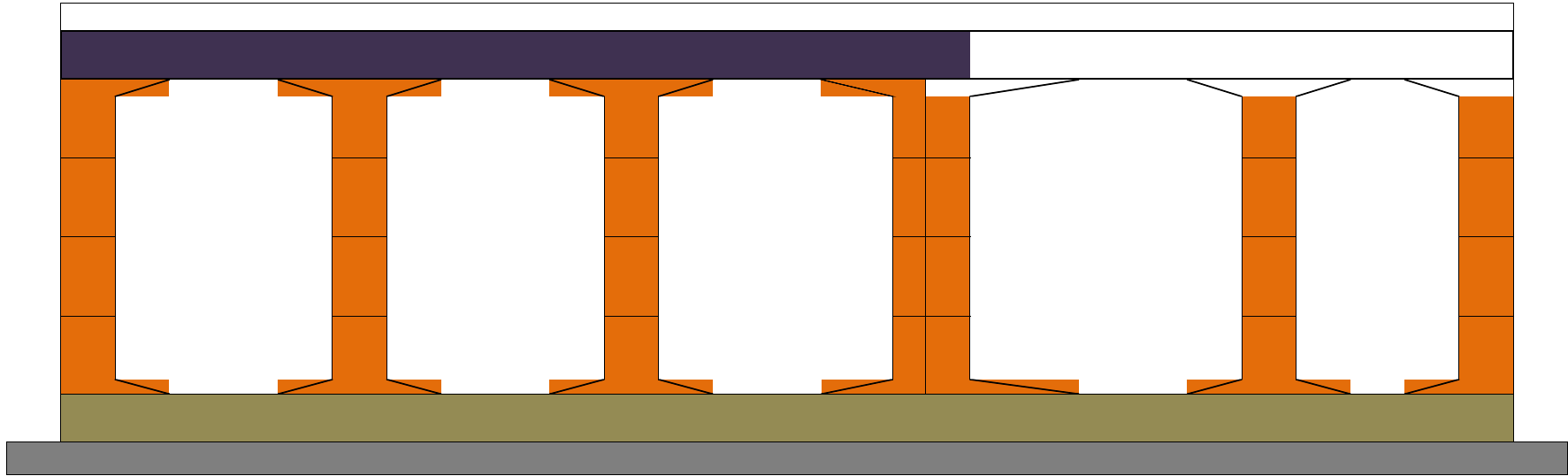

MINOR BRIDGE AT KM. 16+060 (Service Road) LHS

CB
4th Lift
3rd Lift
2nd Lift
1st Lift
Raft
PCC

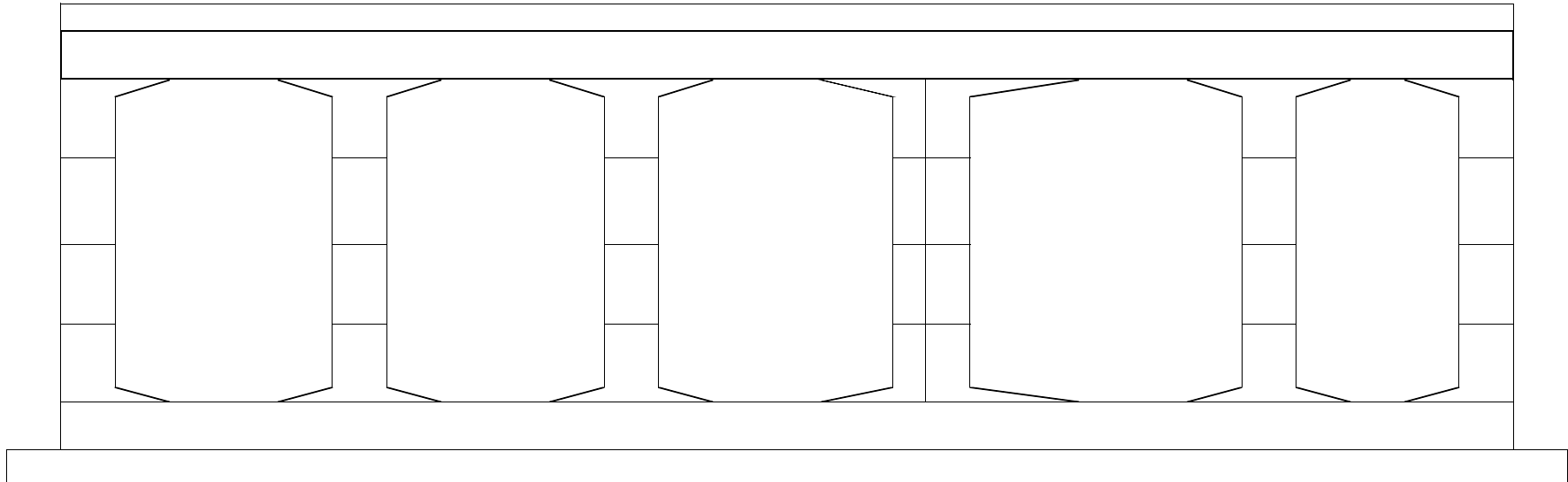

MINOR BRIDGE AT KM. 17+880 RHS

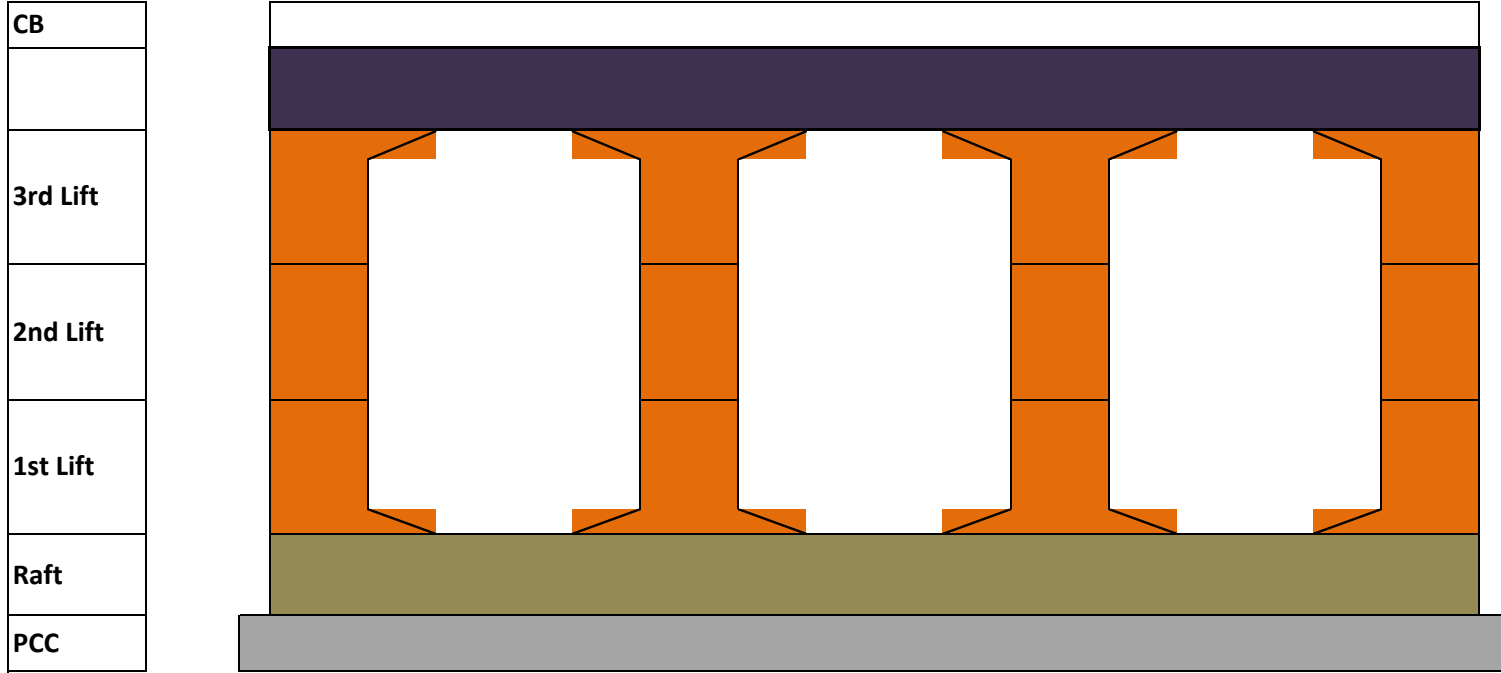

MINOR BRIDGE AT KM. 17+880 LHS

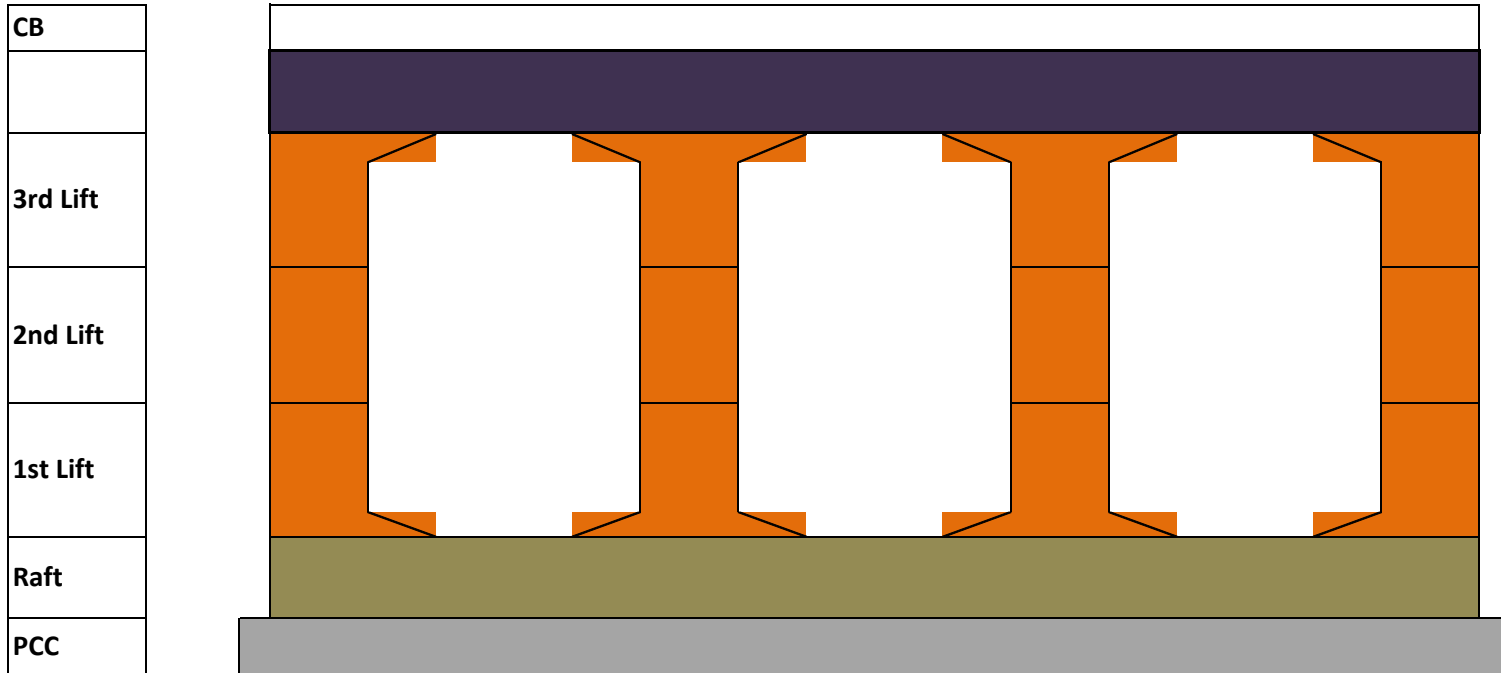

MINOR BRIDGE AT KM. 29+600 RHS

CB

3rd Lift

2nd Lift

1st Lift

Raft

PCC

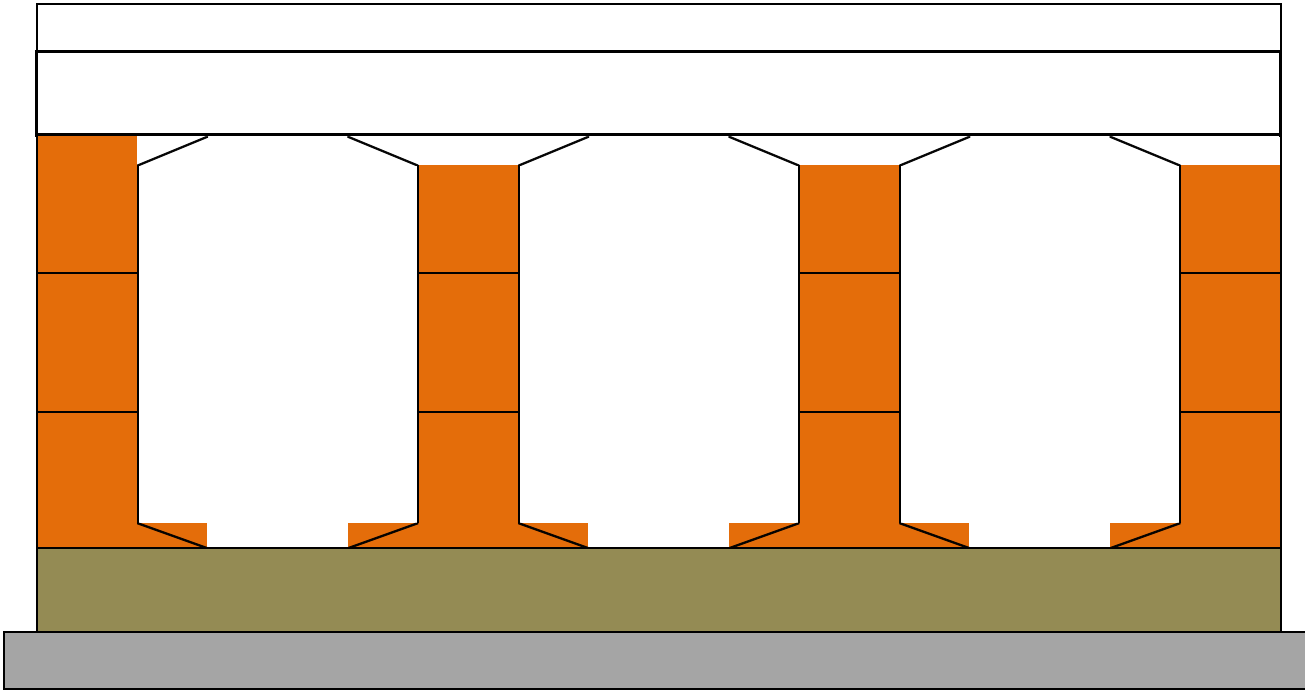

MINOR BRIDGE AT KM. 29+600 LHS

CB

3rd Lift

2nd Lift

1st Lift

Raft

PCC

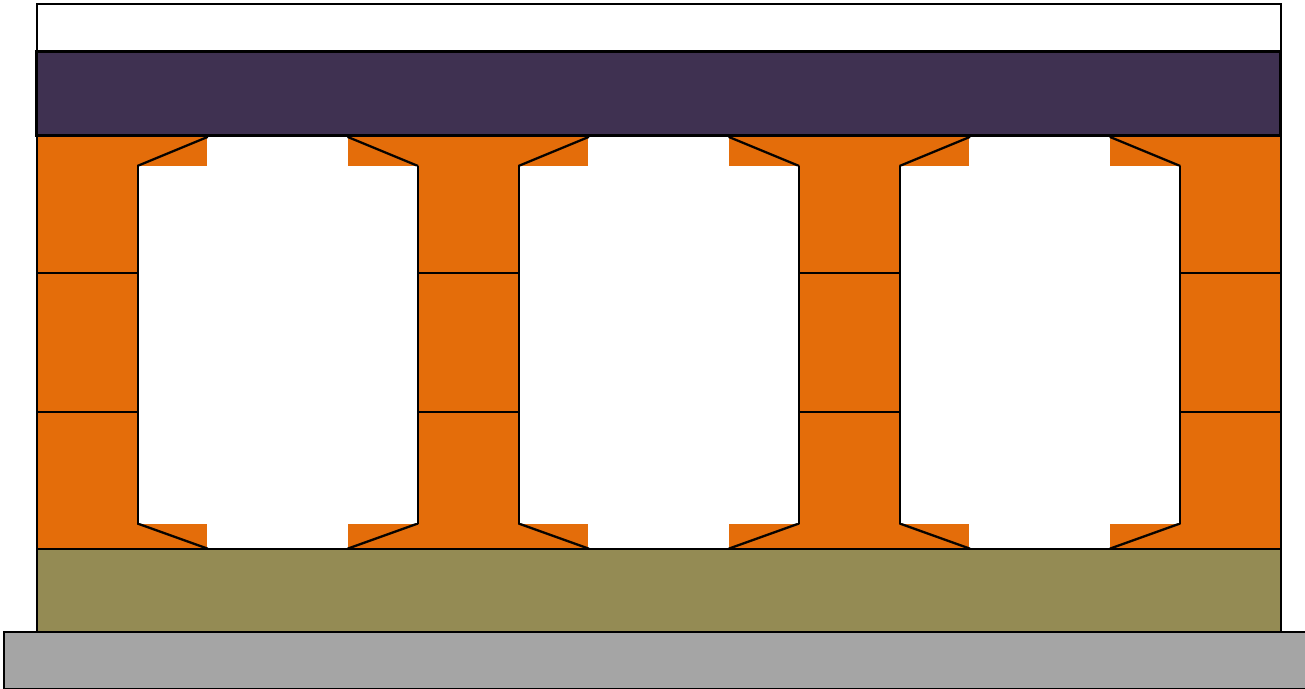

MINOR BRIDGE AT KM. 44+900 RHS

CB

Slab

3rd Lift

2nd Lift

1st Lift

Raft

PCC

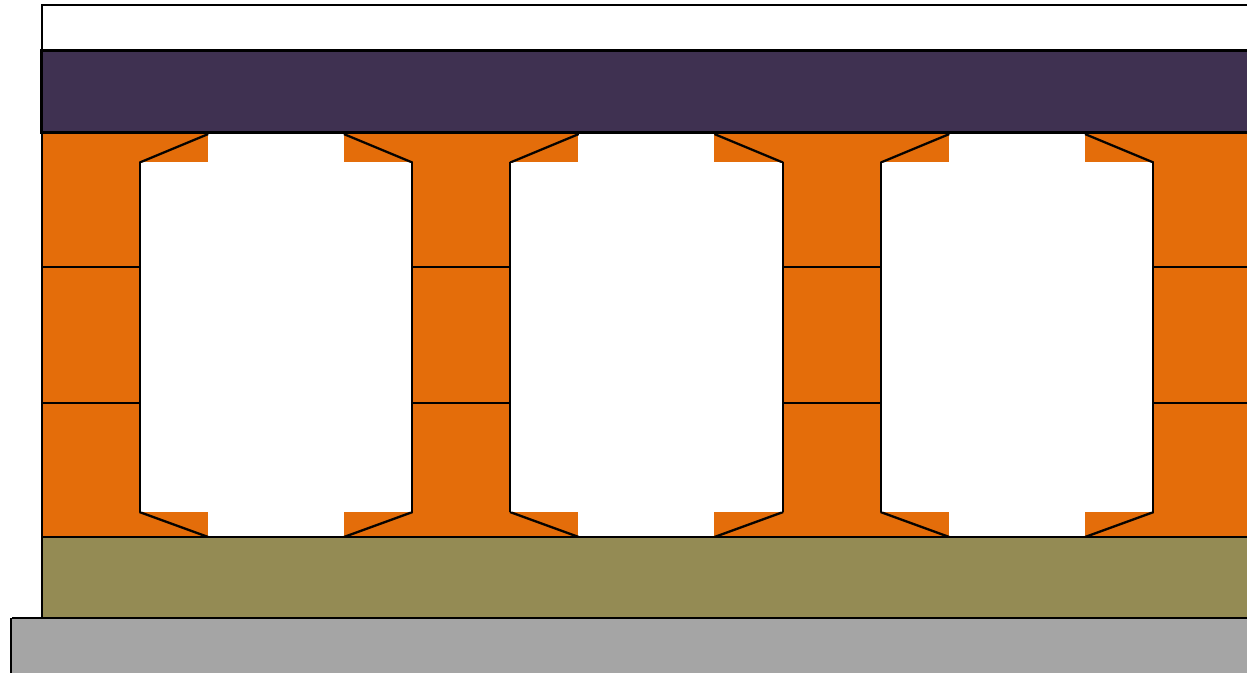

MINOR BRIDGE AT KM. 44+900 LHS

CB

3rd Lift

2nd Lift

1st Lift

Raft

PCC

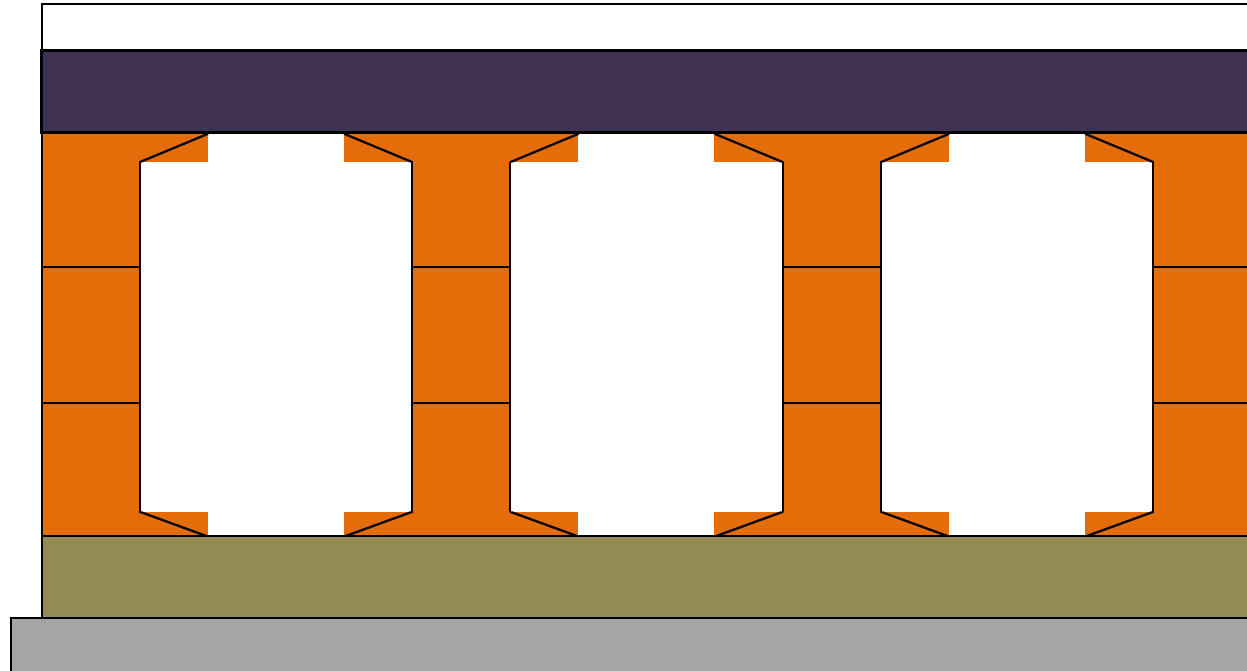

Project:-Construction of 4-lane Road on NH-12 (New NH-52) from Km 299.000 to 346.540 (Design Chainage from 9.860 to 58.740) (Darah-Jhalawar-Teendhar section) in the State of Rajasthan under NHDP Phase-III on Hybrid Annuity Project(Length 48.880 Km.) -Package II

MINOR BRIDGE AT KM. 49+785 (Main Carriage Way) RHS

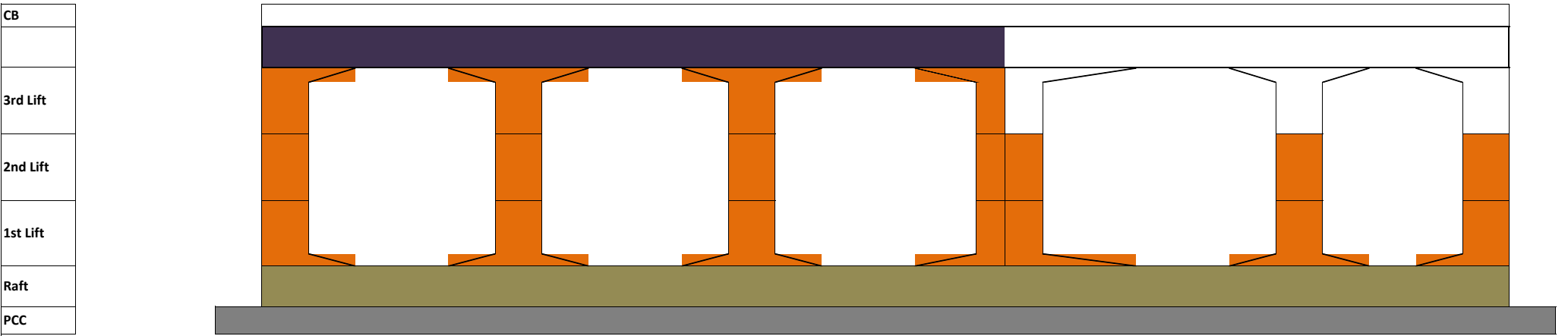

Project:-Construction of 4-lane Road on NH-12 (New NH-52) from Km 299.000 to 346.540 (Design Chainage from 9.860 to 58.740) (Darah-Jhalawar-Teendhar section) in the State of Rajasthan under NHDP Phase-III on Hybrid Annuity Project(Length 48.880 Km.) -Package II

MINOR BRIDGE AT KM. 49+785 (Main Carriage Way) LHS

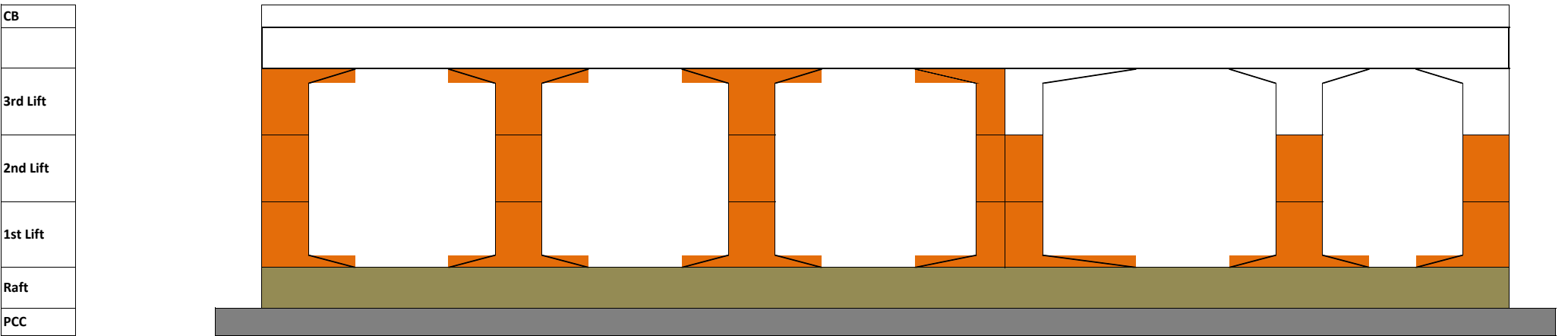

MINOR BRIDGE AT KM. 49+785 (Service Road) RHS

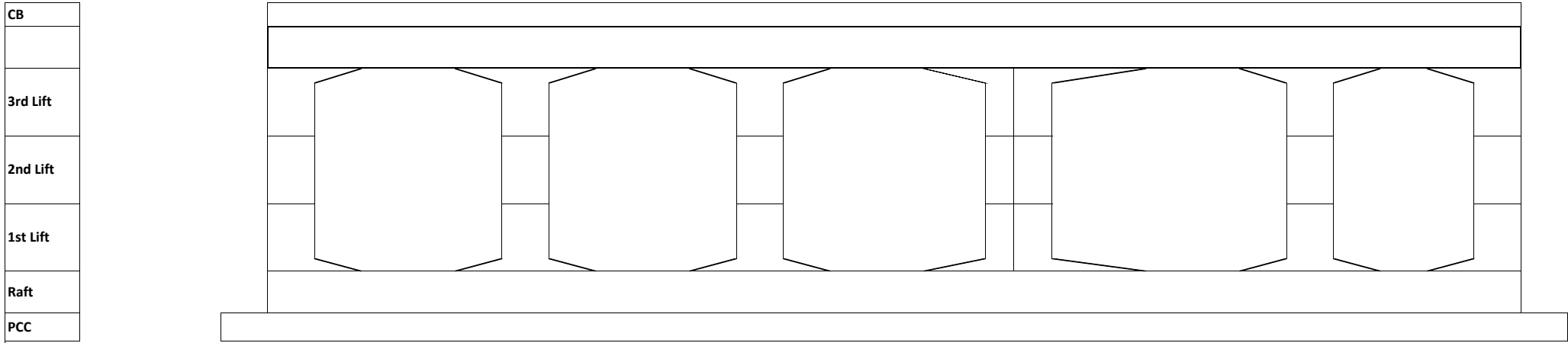

MINOR BRIDGE AT KM. 49+785 (Service Road) LHS

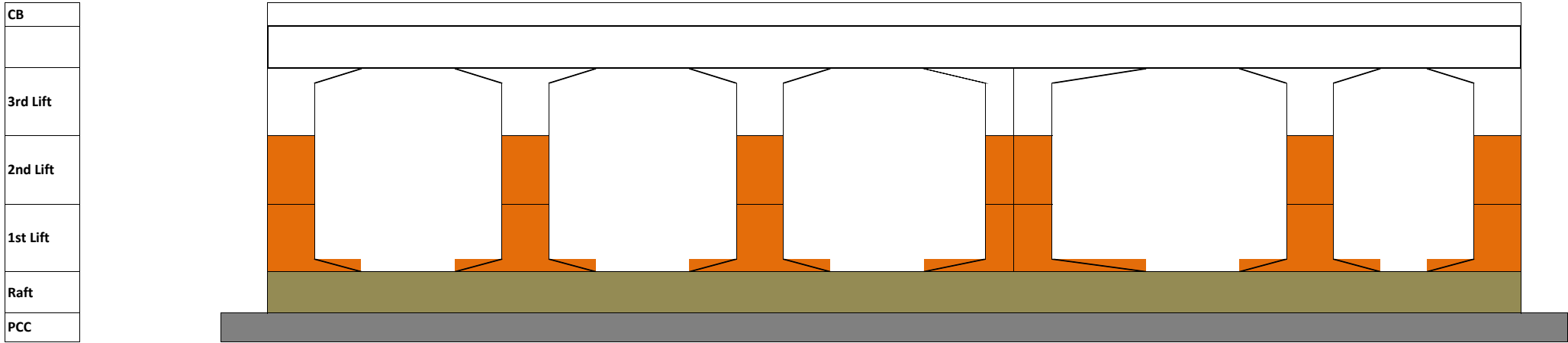

MINOR BRIDGE AT KM. 54+070 RHS

CB
3rd Lift
2nd Lift
1st Lift
Raft
PCC

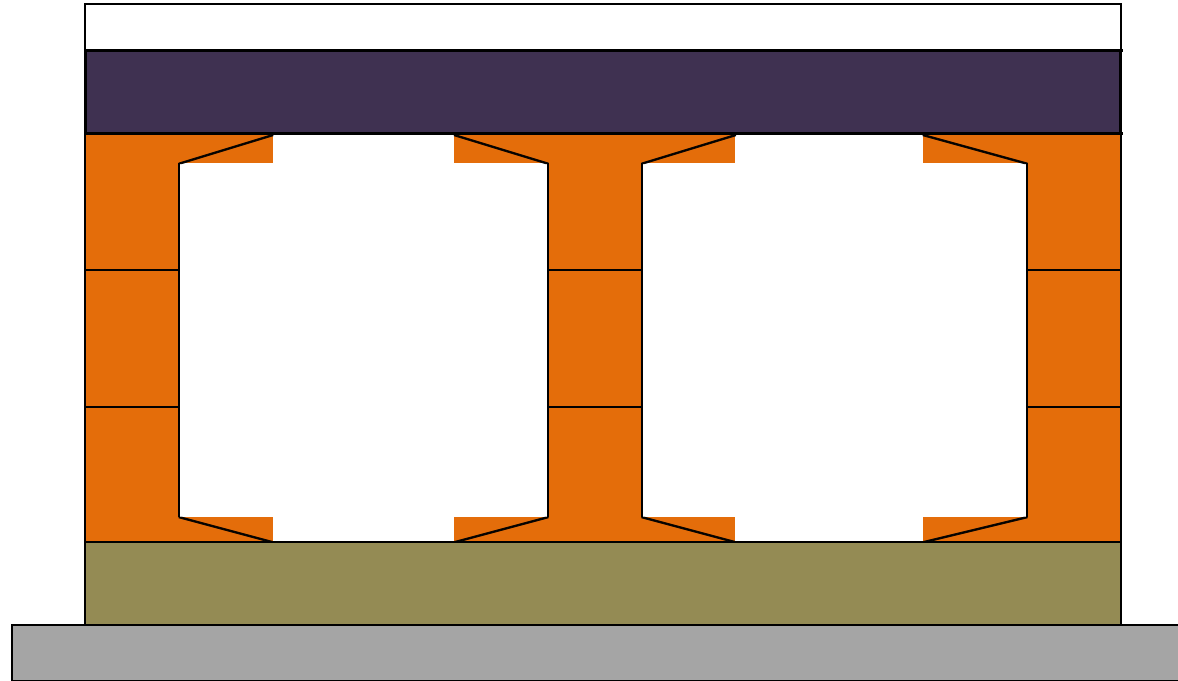

MINOR BRIDGE AT KM. 54+070 LHS

CB
3rd Lift
2nd Lift
1st Lift
Raft
PCC

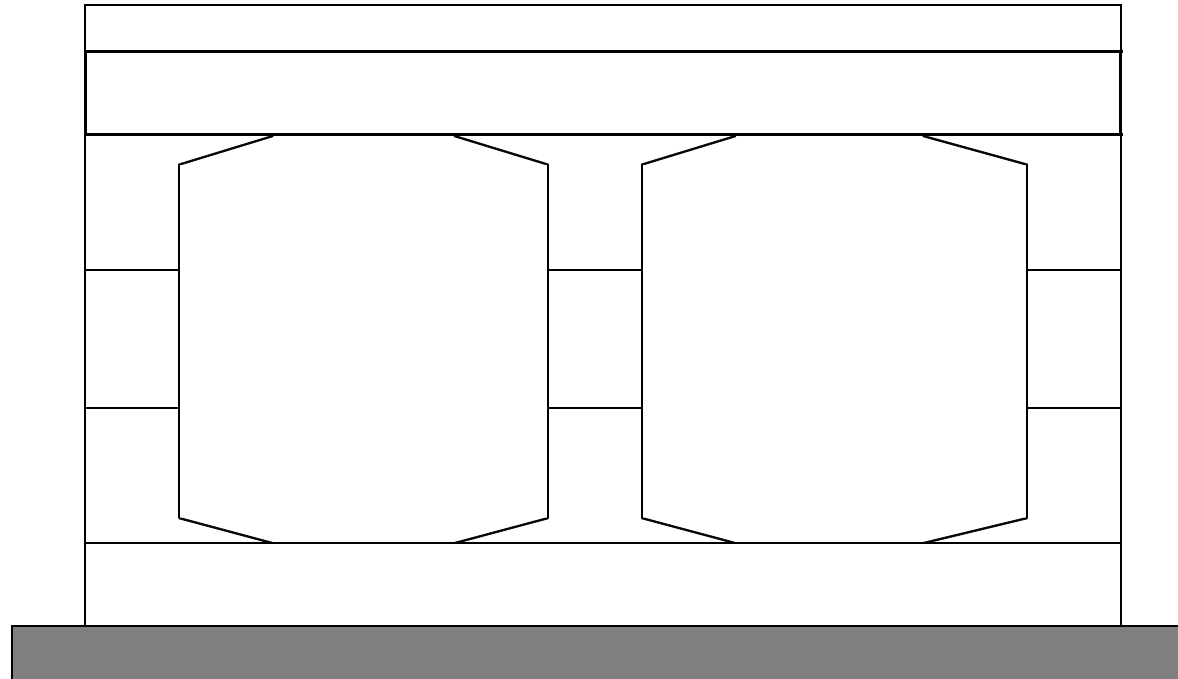

MINOR BRIDGE AT KM. 54+040 RHS

CB
3rd Lift
2nd Lift
1st Lift
Raft
PCC

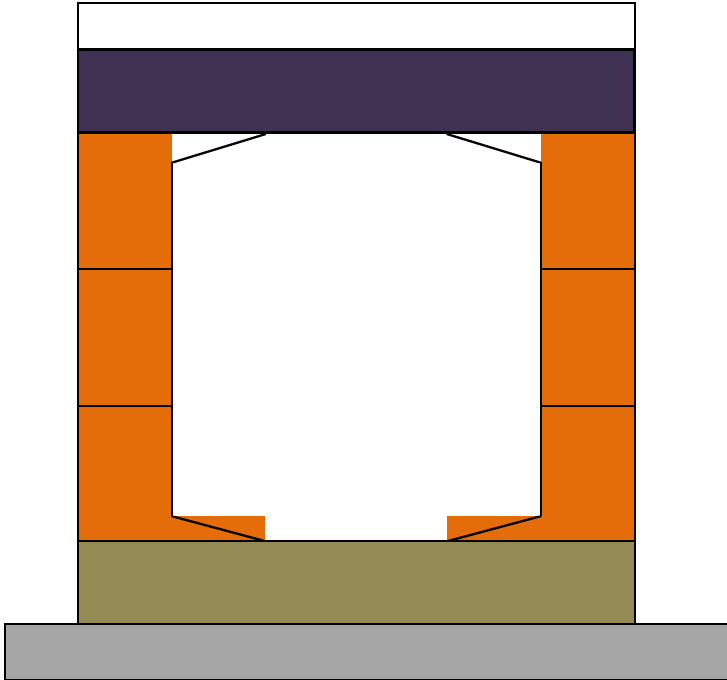

MINOR BRIDGE AT KM. 54+040 LHS

CB
3rd Lift
2nd Lift
1st Lift
Raft
PCC

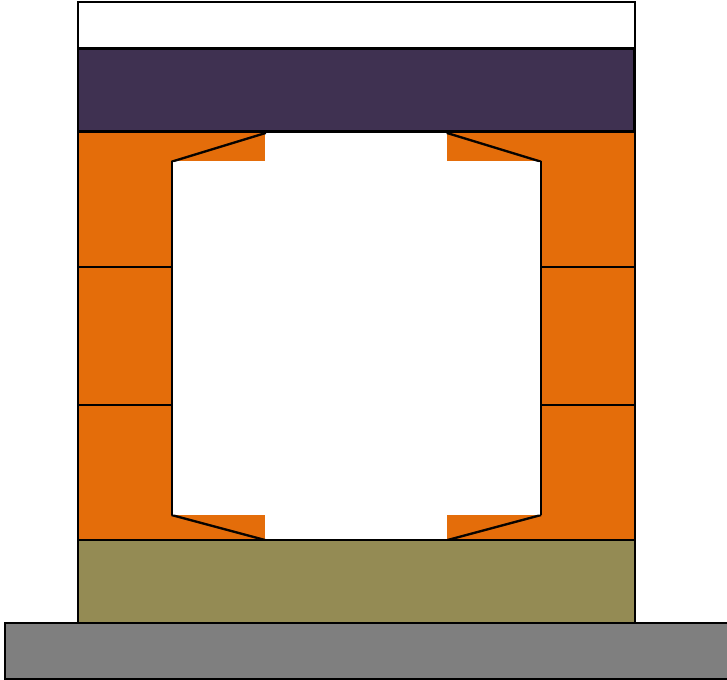



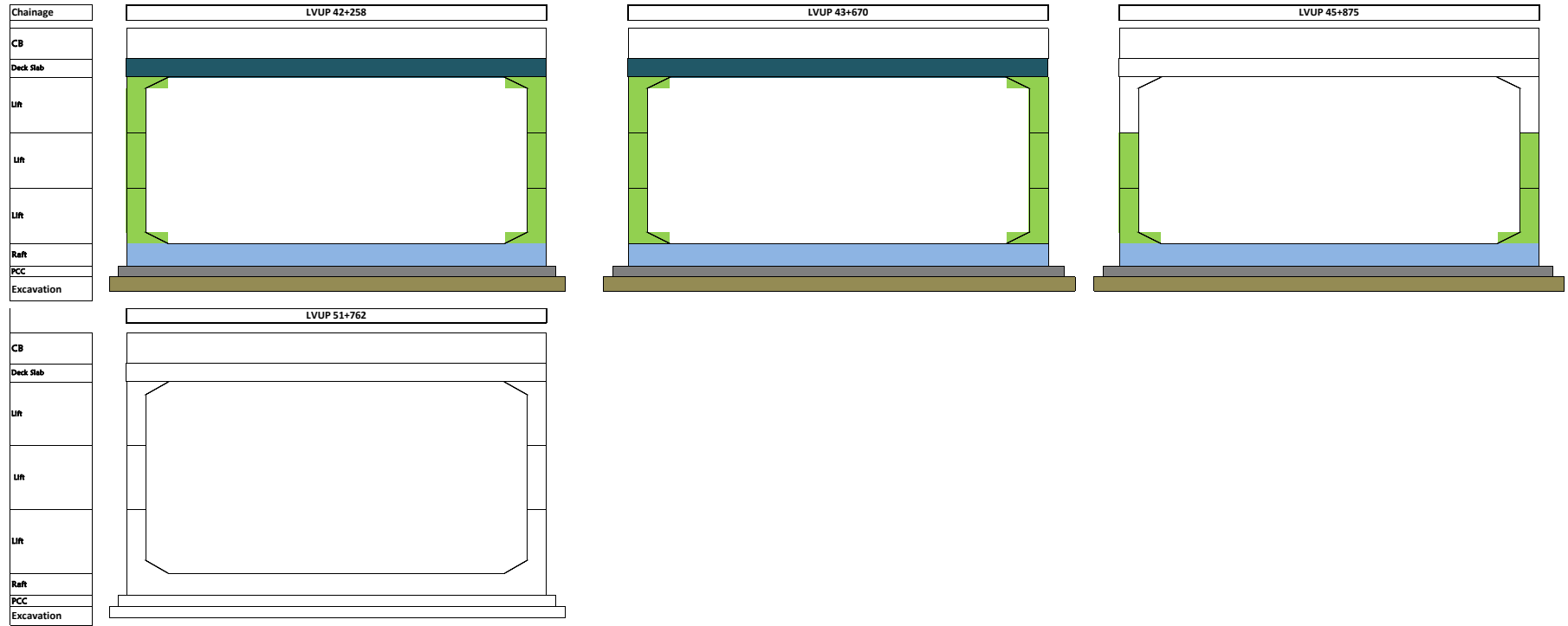

VEHICULAR UNDERPASS AT 12+125 A1 /A2RHS

Slab
Girder placing
Cap
Lift
Lift
Lift
Lift
Lift
Lift
Lift
Raft
PCC

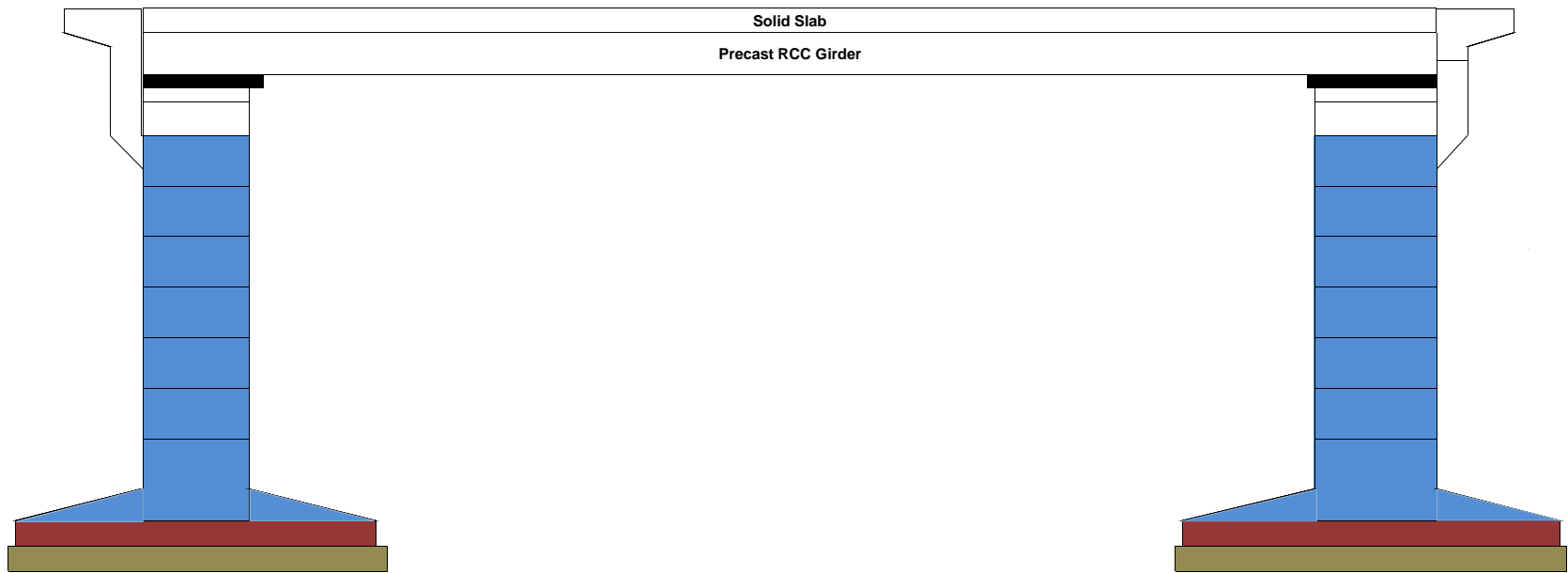

VEHICULAR UNDERPASS AT 12+125A1/ A2 LHS

Slab
Girder placing
Cap
Lift
Lift
Lift
Lift
Lift
Lift
Lift
Raft
PCC

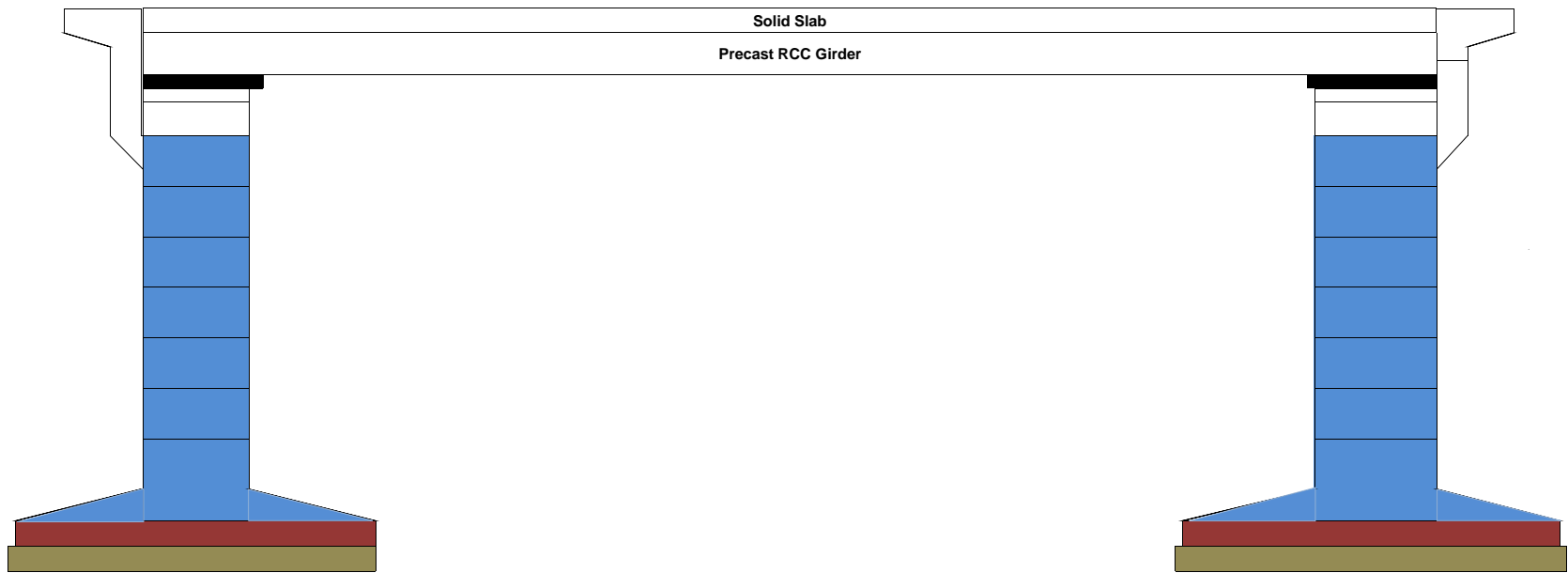

VEHICULAR UNDERPASS AT 15+725 A1/A2 RHS

Slab
Girder placing
Cap
Lift
Lift
Lift
Lift
Lift
Lift
Lift
Raft
PCC

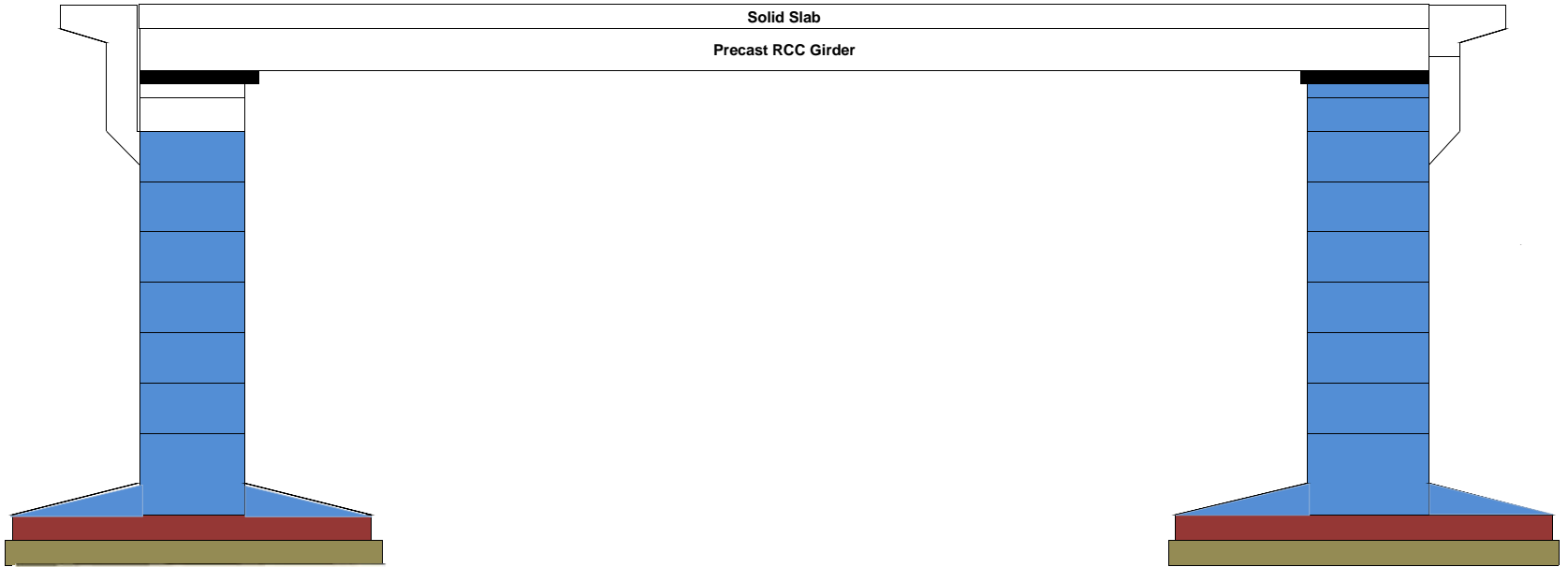

VEHICULAR UNDERPASS AT 15+725 A1/A2 LHS

Slab
Girder placing
Cap
Lift
Lift
Lift
Lift
Lift
Lift
Lift
Raft
PCC

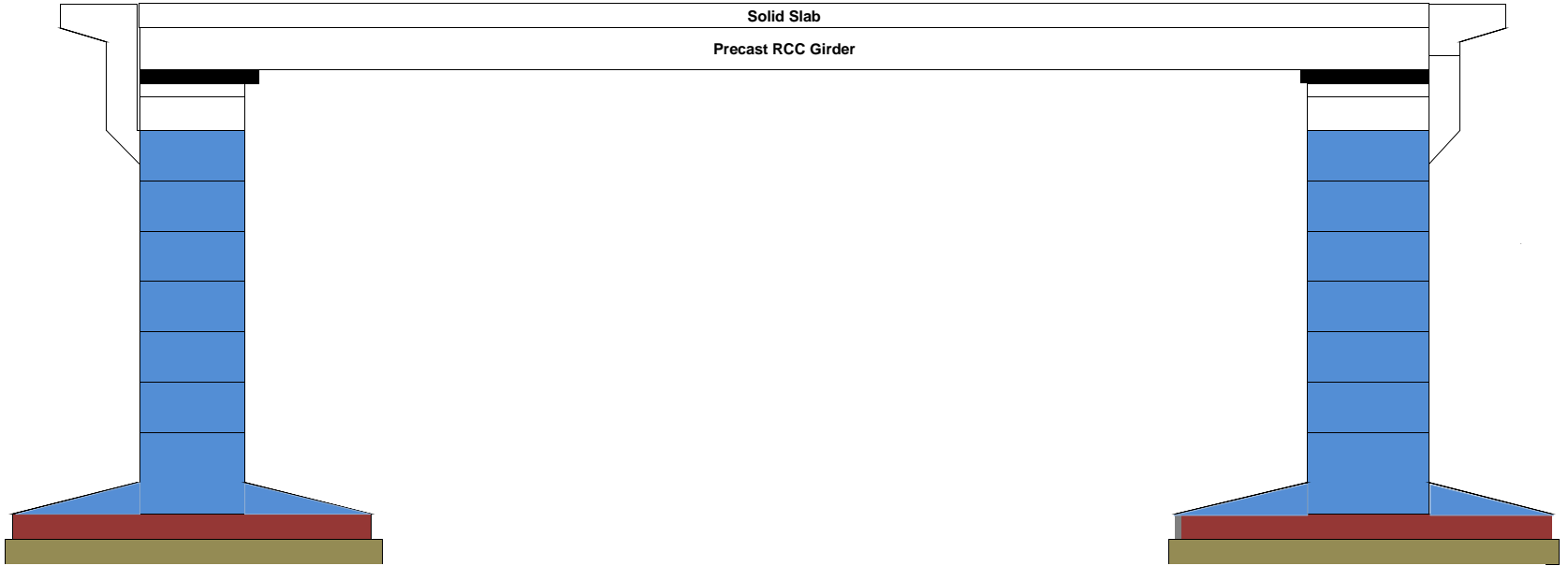

Project:-Construction of 4-lane Road on NH-12 (New NH-52) from Km 299.000 to 346.540 (Design Chainage from 9.860 to 58.740) (Darah-Jhalawar-Teendhar section) in the State of Rajasthan under NHDP Phase-III on Hybrid Annuity Project(Length 48.880 Km.) -Package II

VEHICULAR UNDERPASS AT 25+100 A1/A2 RHS

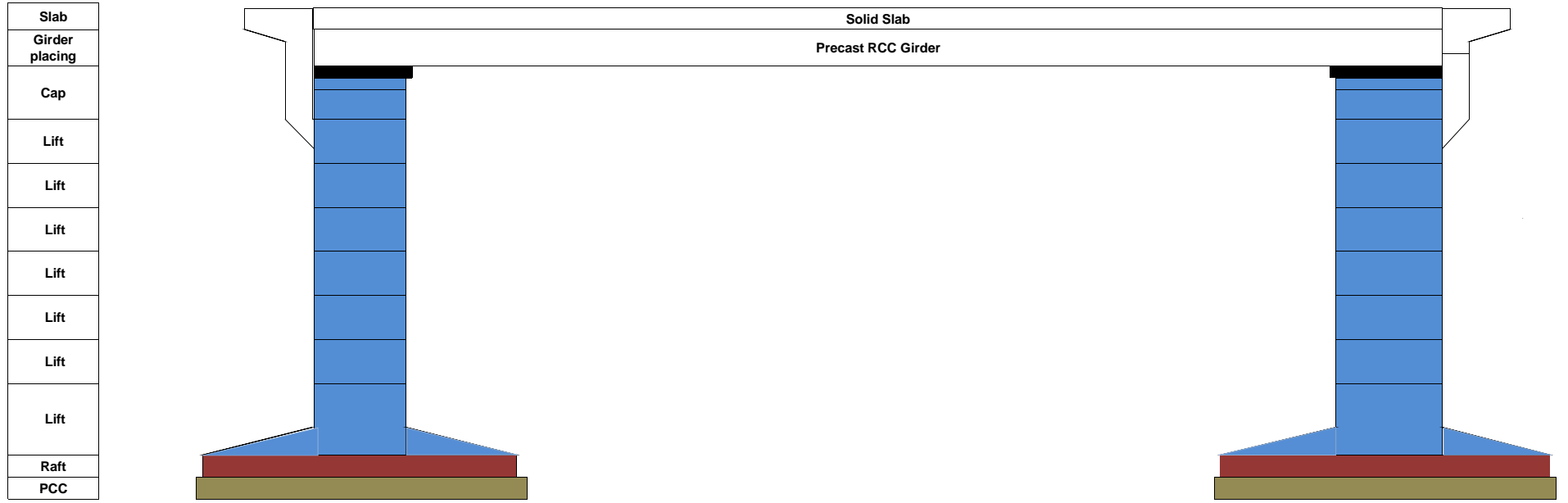

VEHICULAR UNDERPASS AT 25+100 A1/A2 LHS

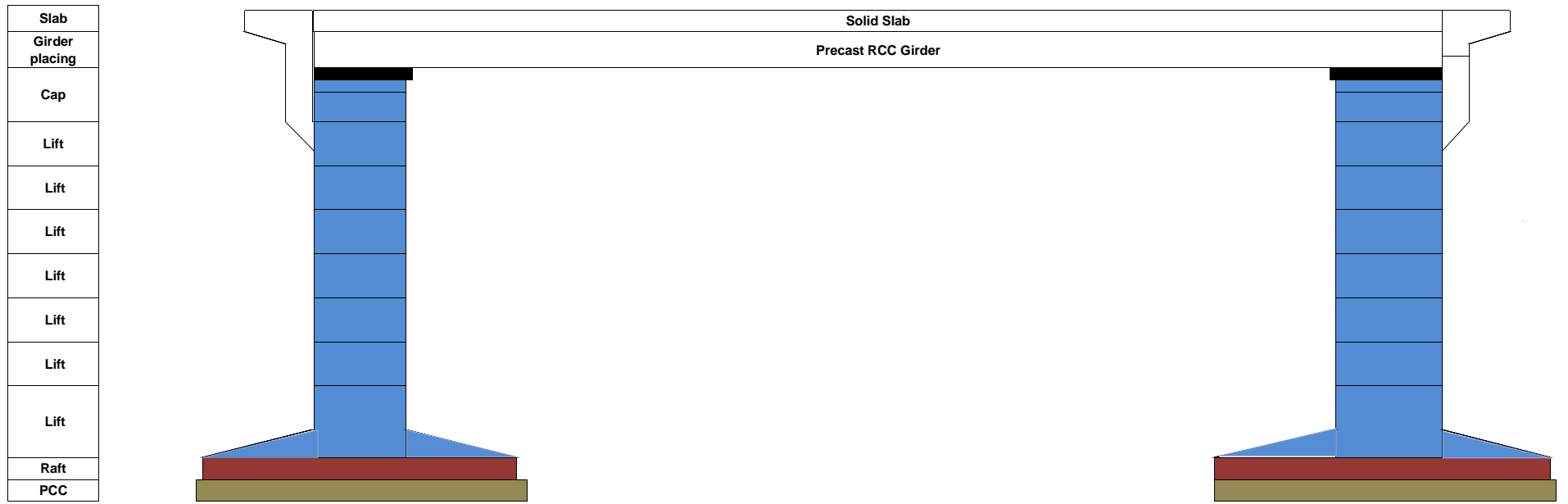

VEHICULAR UNDERPASS AT 27+029 A1/A2 RHS

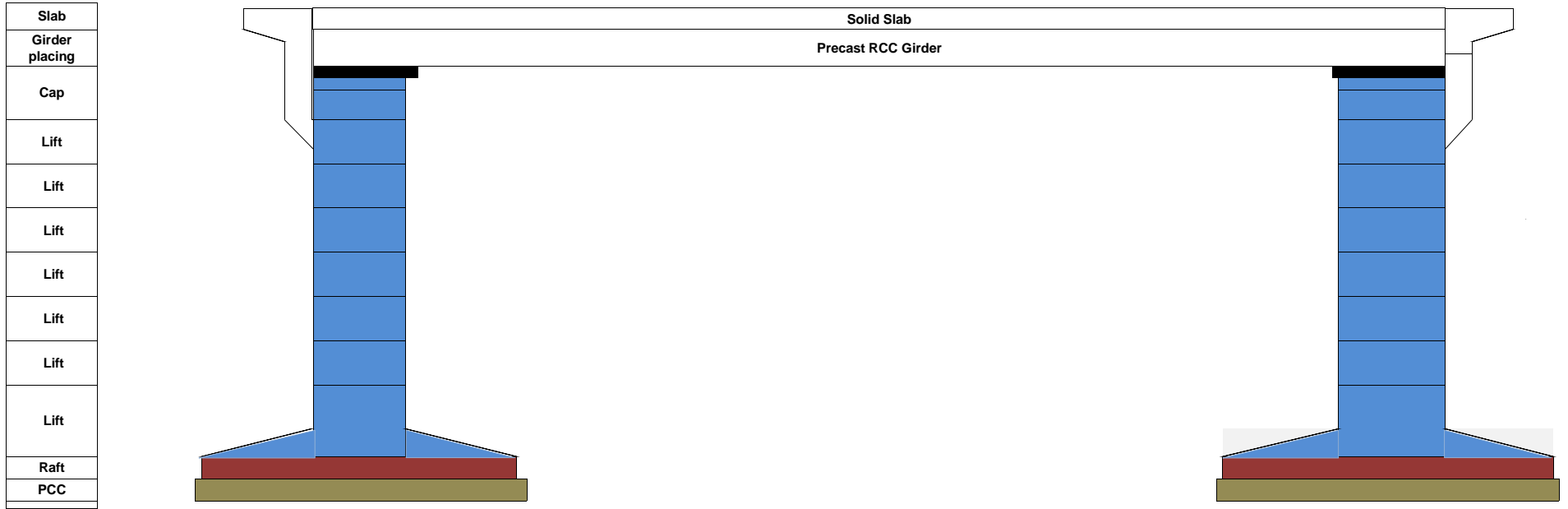

VEHICULAR UNDERPASS AT 27+029 A1/A2 LHS

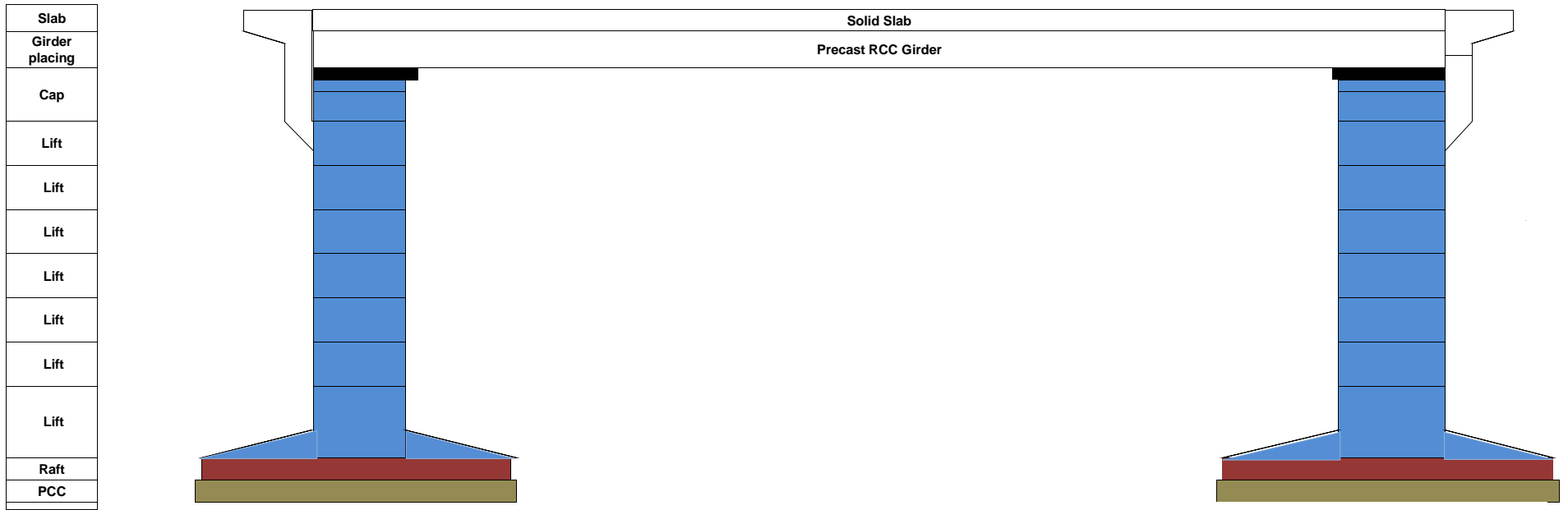

VEHICULAR UNDERPASS AT 30+075 A1/ A2 LHS



VEHICULAR UNDERPASS AT 30+075 A1 /A2RHS



VEHICULAR UNDERPASS AT 41+095 A1/ A2 LHS



VEHICULAR UNDERPASS AT 41+095 A1 /A2RHS



VEHICULAR UNDERPASS AT 49+330A1/ A2 LHS

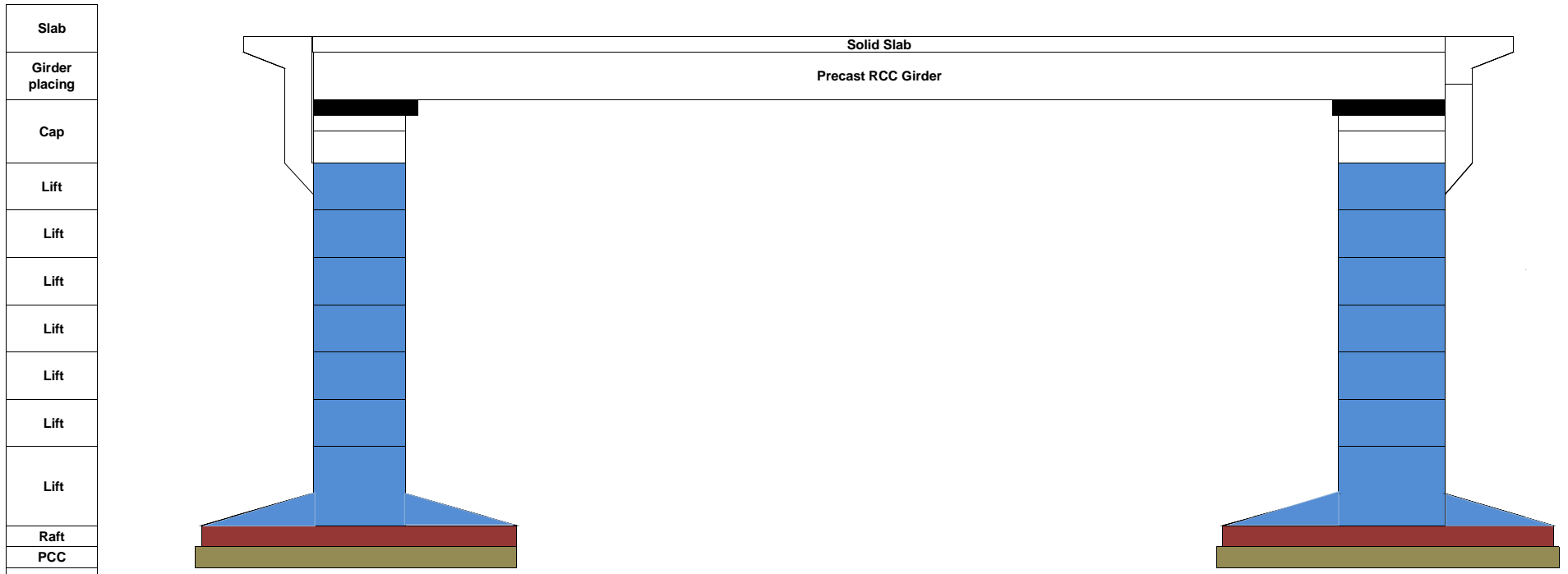

VEHICULAR UNDERPASS AT 49+330 A1 /A2RHS

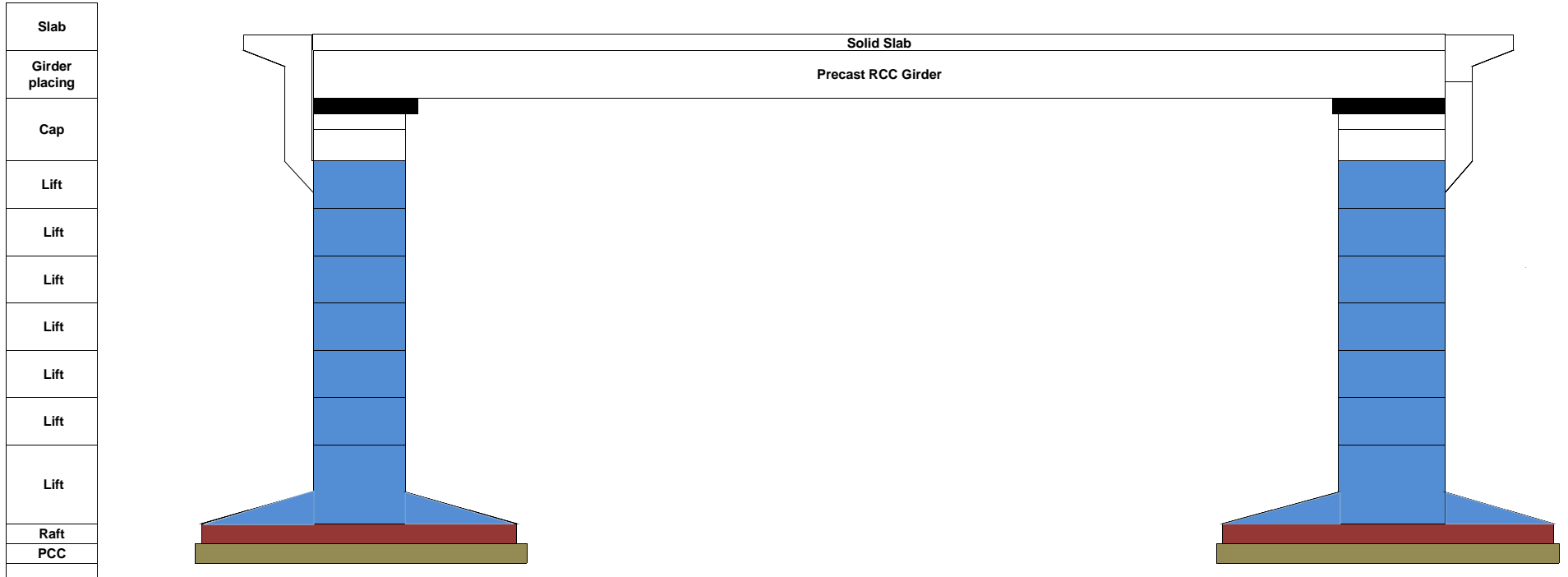

FLYOVER (46+950)LHS

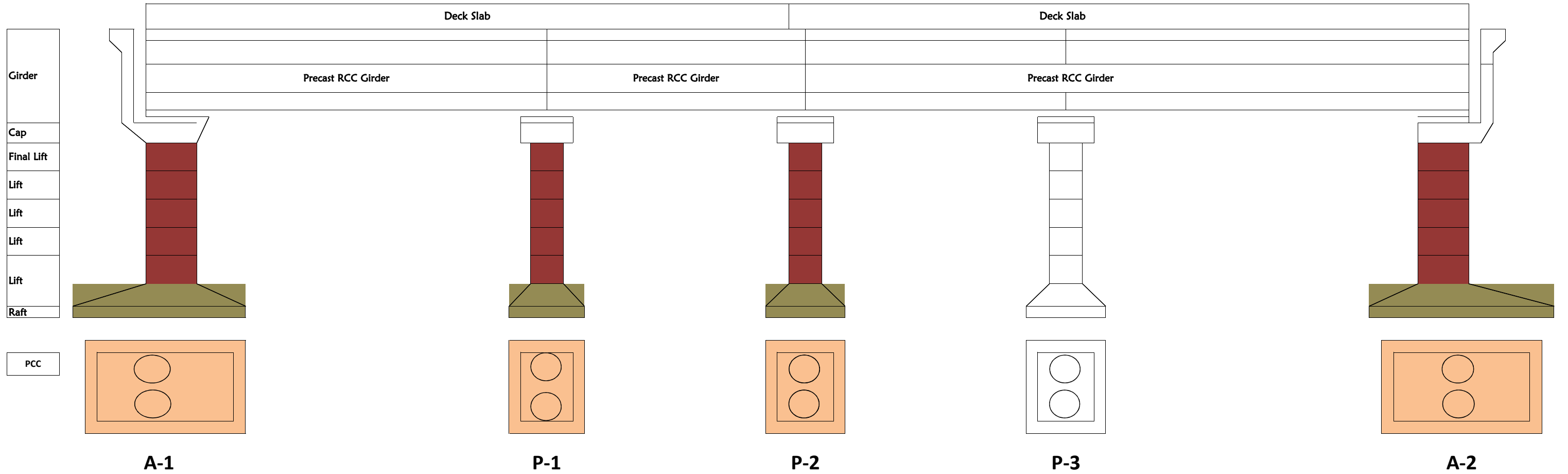

FLYOVER (46+950)RHS

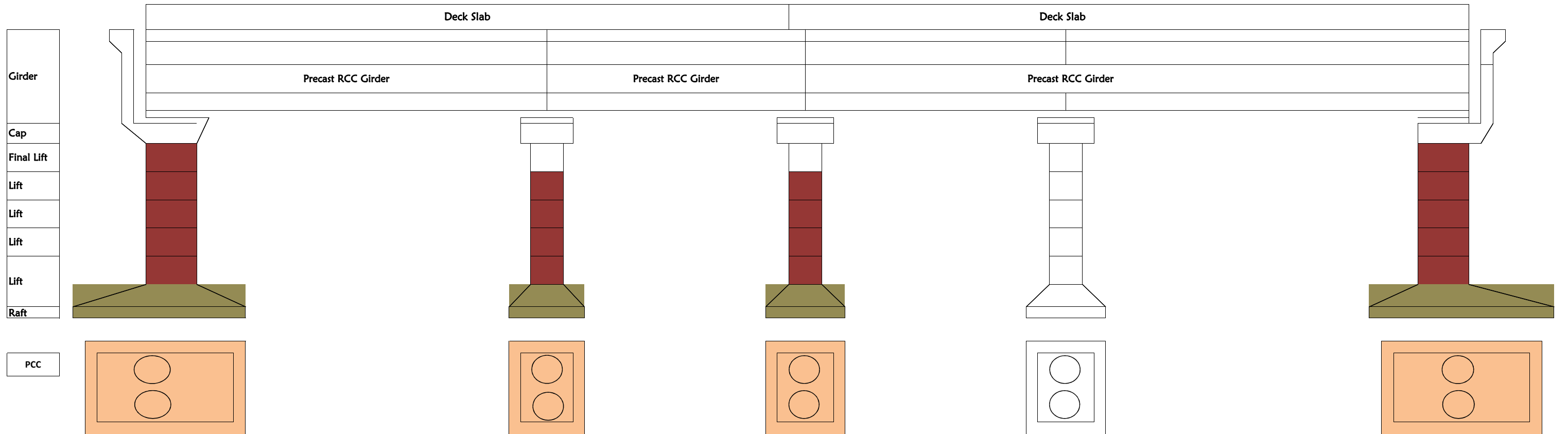

FLYOVER (50+095)RHS

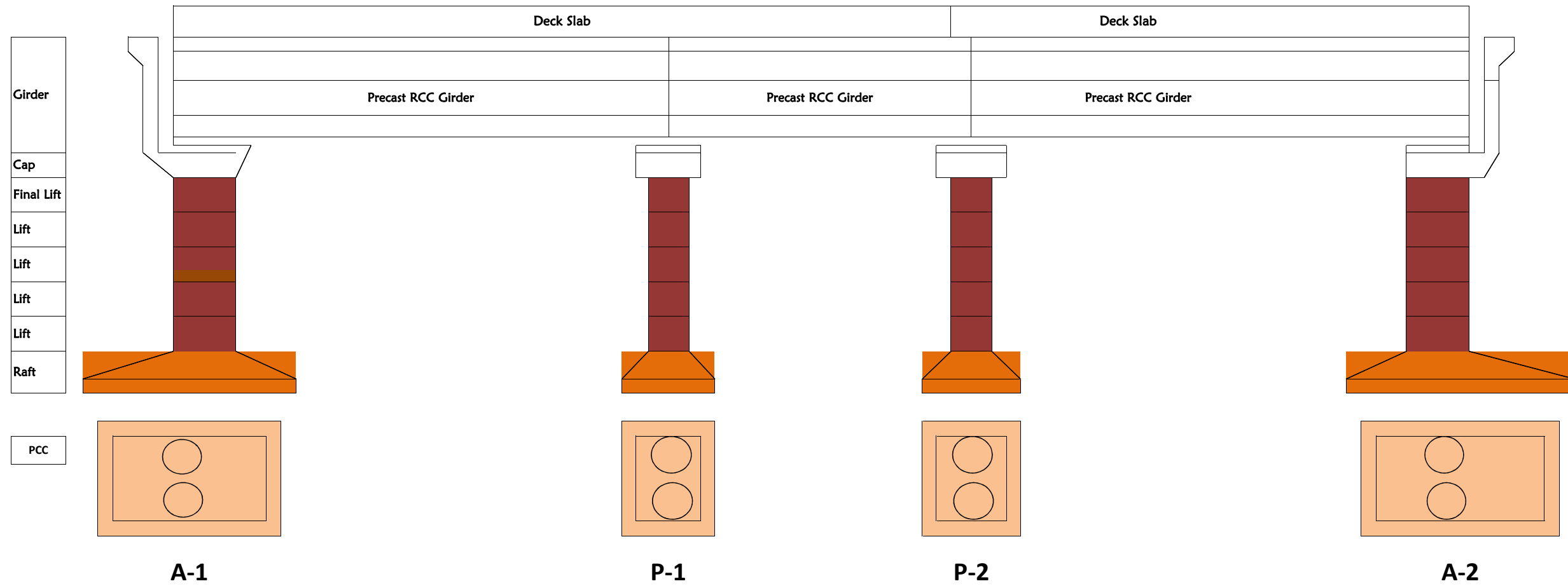

FLYOVER (50+095)LHS

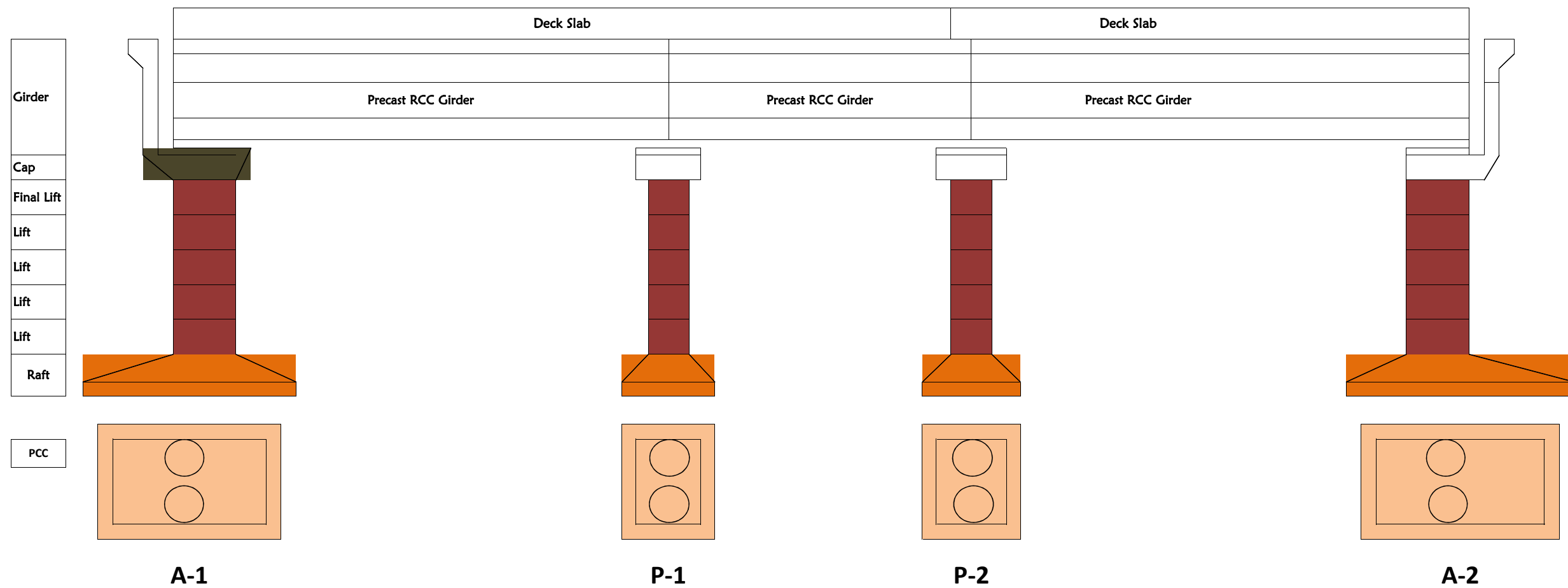

FLYOVER (58+128)LHS

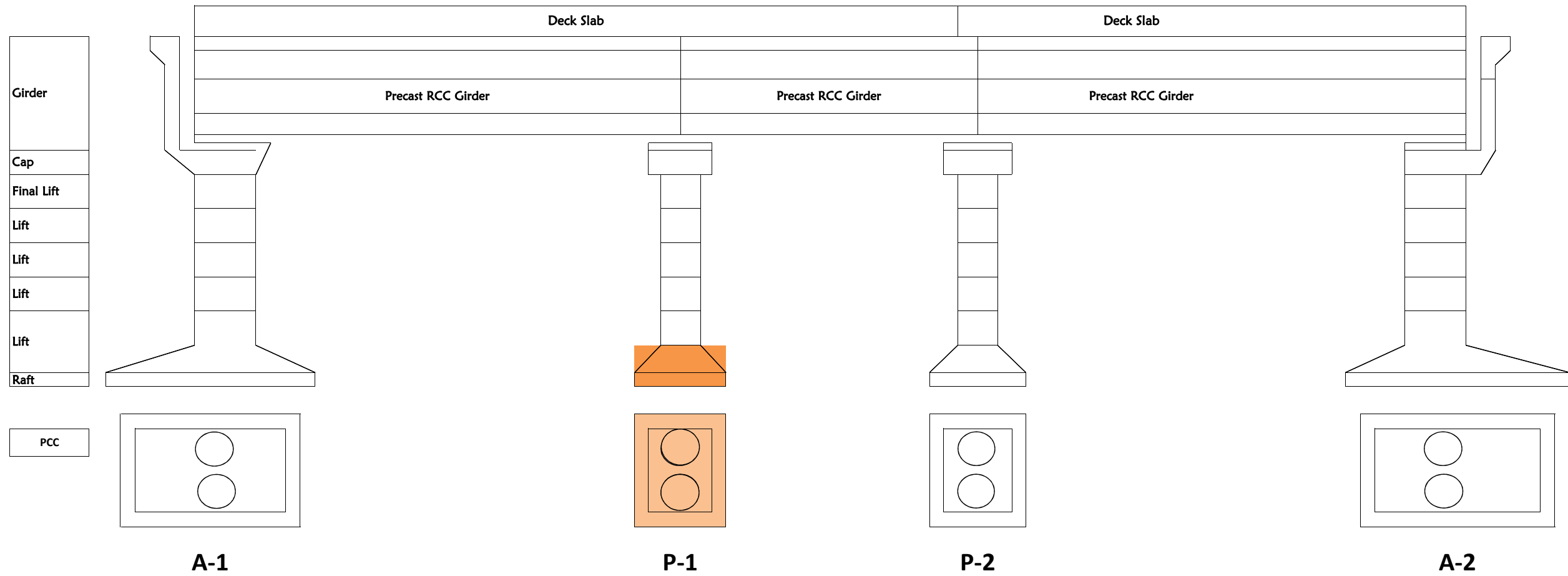

FLYOVER (58+128)LHS

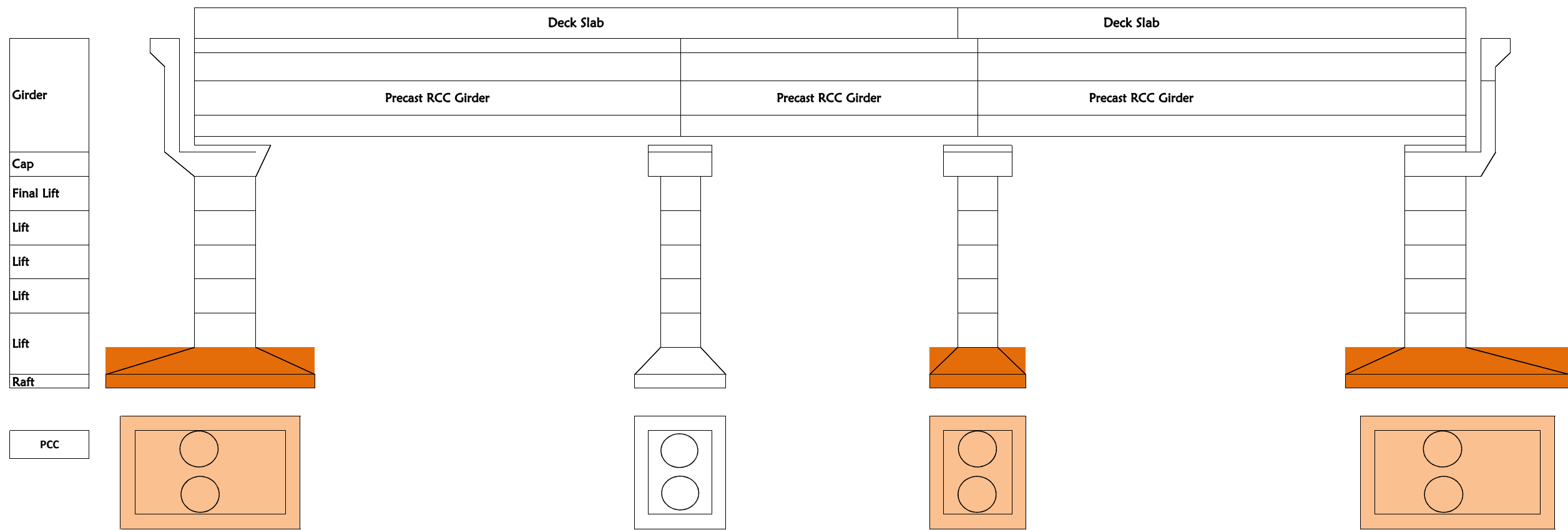

MAJOR BRIDGE AT 36+070 (AHU RIVER) LHS

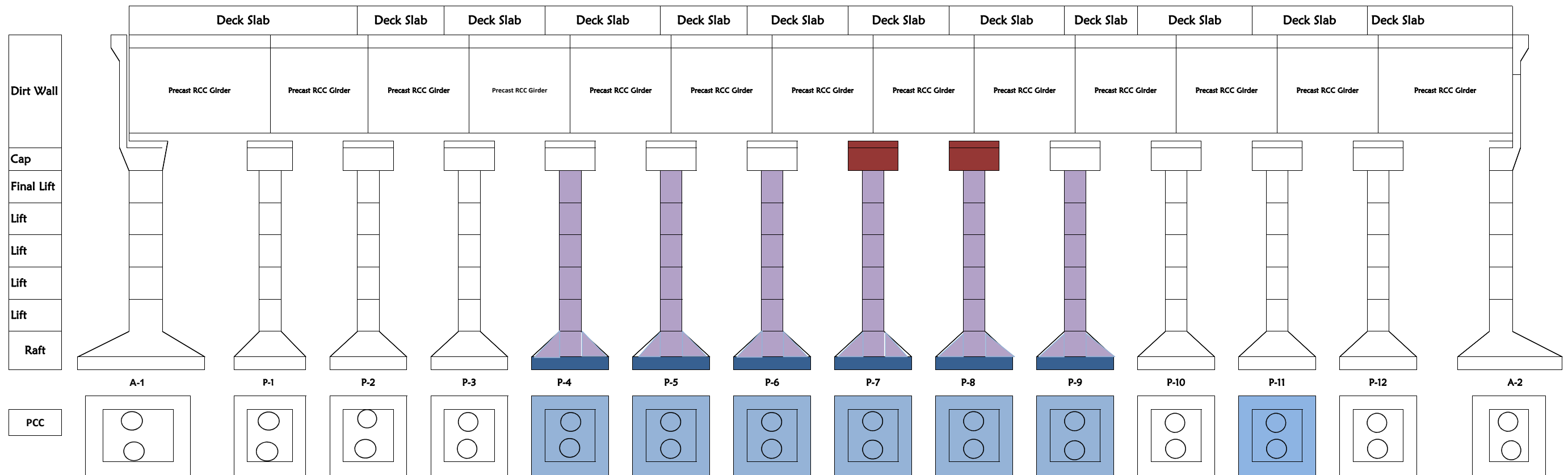

MAJOR BRIDGE AT 36+070 (AHU RIVER) RHS

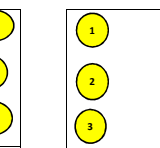
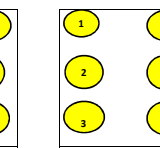
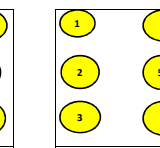
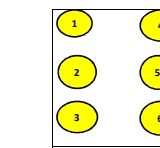
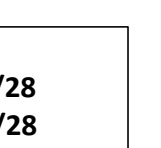
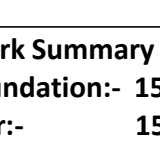
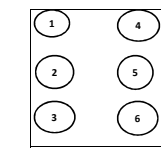
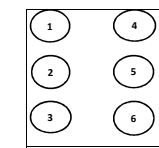
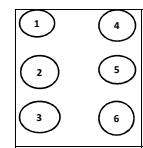
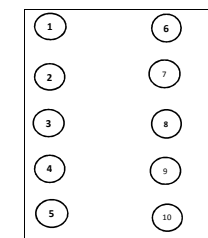
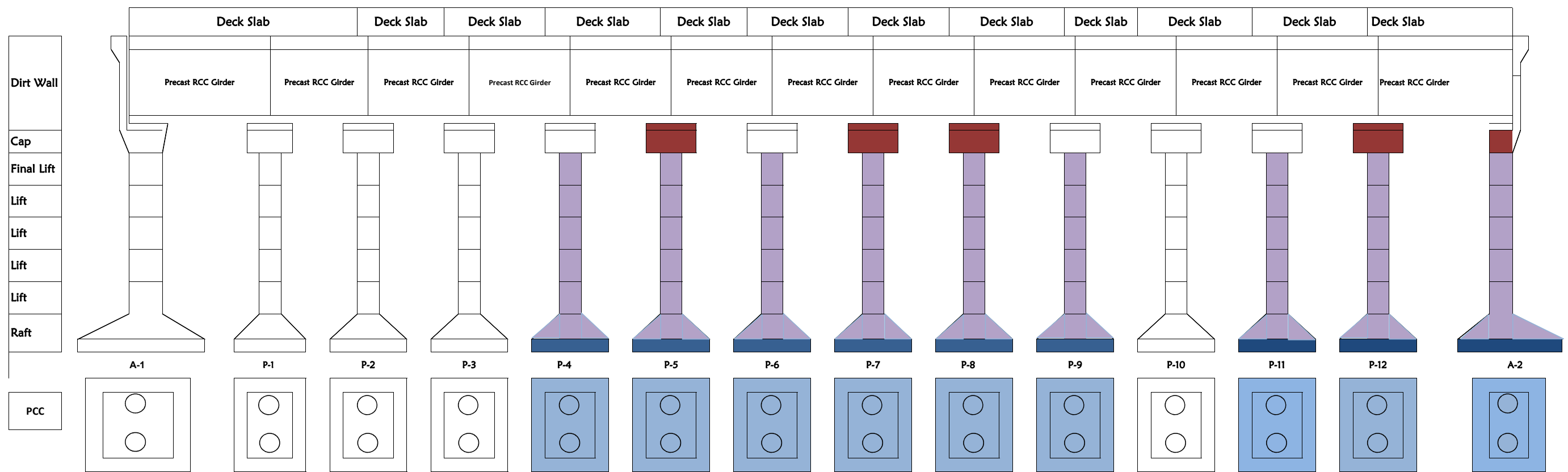

Work Summary
 Foundation:- 15/28
 Pier:- 15/28
 Pier Cap:- 07/28 Pile:- 56/113
 Girder:- 68/130

MAJOR BRIDGE AT 57+127

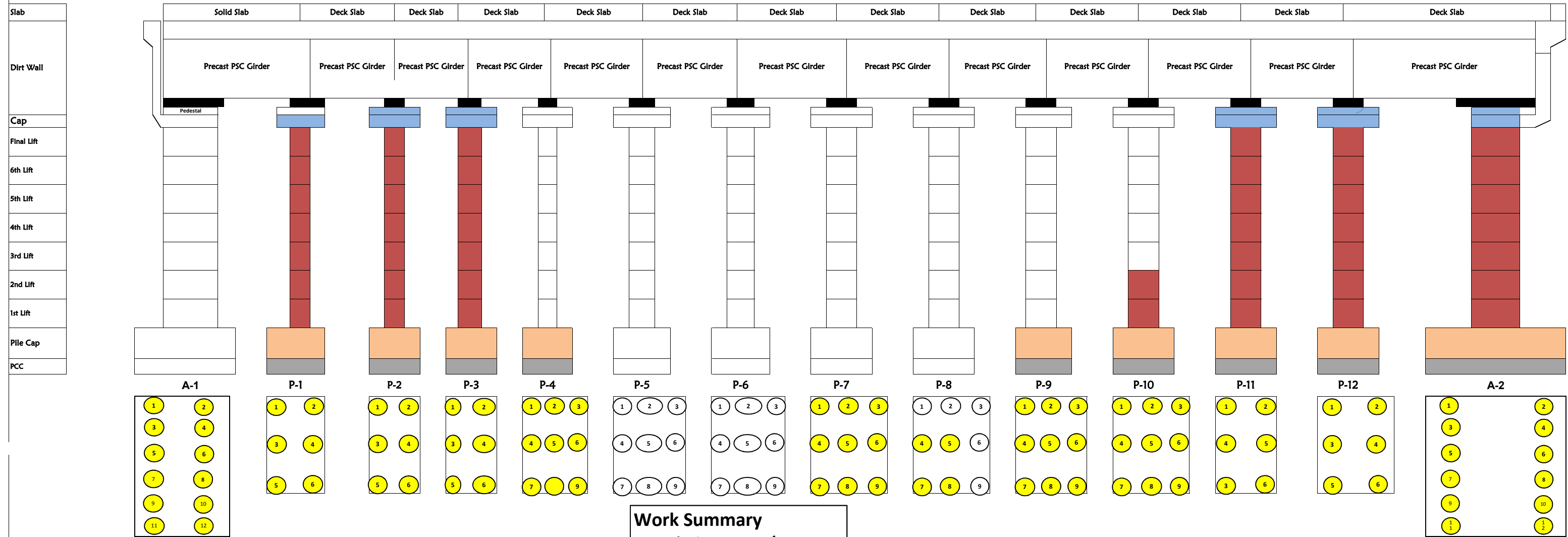

Work Summary
 Foundation:- 10/14
 Pile:- 94/117
 Pile Cap:- 09/14
 Pier:- 06/14
 Pier Cap:- 06/14 Girer
 Casting:- 28/65

Project:-Construction of 4-lane Road on NH-12 (New NH-52) from Km 299.000 to 346.540 (Design Chainage from 9.860 to 58.740) (Darah-Jhalawar-Teendhar section) in the State of Rajasthan under NHDP Phase-III on Hybrid Annuity Project(Length 48.880 Km.) -Package II

FLY OVER + MAJOR BRIDGE(ELEVATED STRUCTURE- 47+450 TO 48+150)LHS

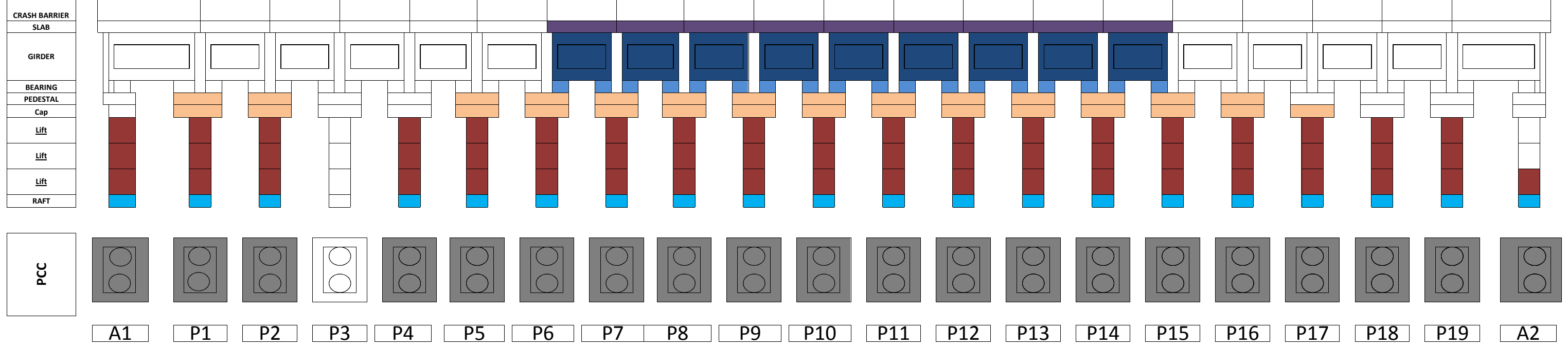



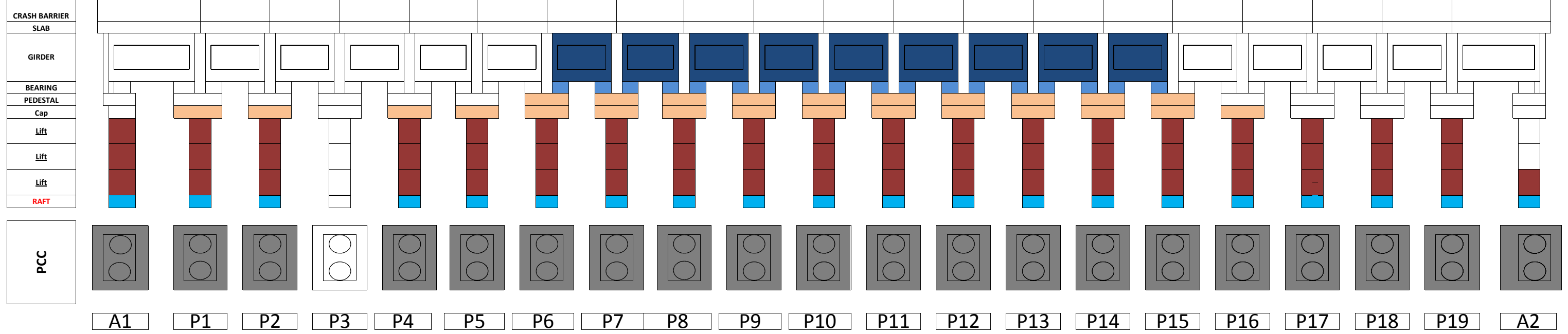





FLY OVER + MAJOR BRIDGE(ELEVATED STRUCTURE- 47+450 TO 48+150) RHS



Work Summary
 Foundation:- 40/42
 Pier:- 38/42
 Pier Cap:- 30/42
 Girders:- 118/200
 Girder Launch:- 90/200



Hindrance Details

No.	Photo	Obstruction Length (m)	LHS-Type of Hindrance	Chainage		RHS-Type of Hindrance	Obstruction Length (m)	Photo	Expected Date of Clearance	Remark's
				From	To					
1				9+860	9+896	Boundary, House & Temple	+36			Disbursement pending by CALA. Boundary wall payment pending. After removal of wall only temple can be reconstructed.
2				9+980	10+020	House, Boundary wall	+40			Award approval is pending from NHA1 for structure.
3		+10	House	10+640	10+650					Award Approval pending for structure from NHA1 Measurement done in July-2019.
4		+10	House	10+670	10+680					Award Approval pending for structure from NHA1 Measurement done in July-2019.
5		+600	Boundry wall, House	11+100	11+700					Disbursement done for some structures. Stay order by civil court
6				10+890	11+000	Compansation problem	+110			Dispute in DM court. Parshottam Jain.
7		+60	House	12+315	12+375					Disbursement is done but not removed due to differenciation of compansation
8		+100	Service Station	20+160	20+260					Difference of Award measurement of structure is under process between NHA1/LAO
9		+80	Compansation problem	20+650	20+730	Compansation problem	+80			Disbursement ok, but Hindrance not removed from Land owner due to difference of compensation
10				20+750	20+830	Factory	+80			Land & structure award (Matter in SDM Court)
11		+50	Shop, Boundary & Land Compansation problem	23+800	23+850					Well & Tubewell difference award approval pending between NHA1/LAO
12		+100	Structure, Land	24+000	24+100					Difference of Agriculture / commercial Land compensation under process in LAO since 6 month

Name of Work:-Construction of 4-Lane Road on NH-12 (New NH-52) from Km 299.000 to 346.540 (Design Chainage from 9.860 to 58.740) (Darah-Jhalawar-Teendhar section) in the state of Rajasthan under NHDP Phase-III on Hybrid Annuity Project (Length 48.880 Km)-Package II

Annexure-I

Hindrance Details

No.	Photo	Obstruction Length (m)	LHS-Type of Hindrance	Chainage		RHS-Type of Hindrance	Obstruction Length (m)	Photo	Expected Date of Clearance	Remark's
				From	To					
13				24+270	24+680	House ,Temple, Boundary wall, Hauz, etc.	+410			Some Villagers are unsatisfied for award done by NHAI, community land disbursement pending
14		+670	Hand pump,Toilet, Verandah,Sewer tank, Boundary wall, etc	24+270	24+940					Some Villagers are unsatisfied for award done by NHAI. Land disbursement of compensation pending from LAO.
15				25+570	25+580	Chabutra & Well	+10			Well Award approval pending between NHAI/LAO
16		+85	Compansation problem	30+500	30+585	Compansation problem	+85			Compansation pending in SDM court
17		3+500	DLC problem	32+500	36+000	DLC problem	3+500			Compansation pending
18		+100	Land	41+200	41+300					Compansation pending due to High court-cases. Rekha Lalwani
19				42+330	42+400	Land	+70			Devi lal. For decission on compansation pending due to court-cases through SDM on 11.09.2019
20		+700	DLC problem	51+400	52+100	DLC problem	+700			Compansation pending
21				55+600	55+700	Orange Garden	+100			Ram Prasad. Villagers forcefully stopped the work due to demanding orange trees compensation
22				56+000	56+700	Orange Garden	+700			Villagers forcefully stopped the work due to demanding orange trees compensation(Matter in Court)
Total		6+065					5+921			

